

April 29, 2011

Nuclear and Industrial Safety Agency

Seismic Damage Information (the 120th Release)
(As of 15:00 April 29, 2011)

Nuclear and Industrial Safety Agency (NISA) confirmed the current situation of Onagawa NPS, Tohoku Electric Power Co. Inc.; Fukushima Dai-ichi and Fukushima Dai-ni NPSs, Tokyo Electric Power Co. Inc. (TEPCO); Tokai Dai-ni NPS, Japan Atomic Power Co. Inc. as follows:

Major updates are as follows.

1. Nuclear Power Stations (NPSs)

● Fukushima Dai-ichi NPS

- The operation of gradually changing the amount of water for injection to the Reactor Pressure Vessel, from about 6m³/h to the maximum of about 14m³/h, was started. (10:02 April 27) After carrying out the injection at 10m³/h, the injection rate was changed back to 6m³/h. (10:14 April 29)
- In order to carry out inspections, etc. of the transfer facilities, the transfer of stagnant water from the Turbine Building Trench of Unit 2 (Stagnant water of high-level dose) to the Radioactive Waste Treatment Facility was suspended. (9:16 April 29)
- Full-scale implementation of spraying anti-scattering agent was carried out in the area of about 4,540 m² on the mountain-side of the reactor building of Unit 5 and on the surface of the slope in front of the Former Main Office Building. (From 10:30 till 12:00 April 28)
- Removal of rubble (Amounts equivalent to 4 containers) using remote-control heavy machineries was carried out. (From 9:00 till 16:00 April 28).

For more information: NISA English Home Page
<http://www.nisa.meti.go.jp/english/index.html>

April 30, 2011

Nuclear and Industrial Safety Agency

Seismic Damage Information (the 121st Release)
(As of 12:00 April 30, 2011)

Nuclear and Industrial Safety Agency (NISA) confirmed the current situation of Onagawa NPS, Tohoku Electric Power Co. Inc.; Fukushima Dai-ichi and Fukushima Dai-ni NPSs, Tokyo Electric Power Co. Inc. (TEPCO); Tokai Dai-ni NPS, Japan Atomic Power Co. Inc. as follows:

Major updates are as follows.

1. Nuclear Power Stations (NPSs)

● Fukushima Dai-ichi NPS

- Full-scale implementation of spraying anti-scattering agent was carried out in the area of about 7,000 m² on the ocean-side of the turbine building of Unit 4 using an unmanned crawler dump. (From 09:00 till 16:00 April 29)
- Full-scale implementation of spraying anti-scattering agent was carried out by workers in the area of about 5,800 m² on the mountain-side of the reactor building of Unit 5, the road in front of the Former Main Office Building and around the gymnasium. (From 10:30 till 14:00 April 29)
- Removal of rubble (amounts equivalent to 4 containers) using remote-control heavy machineries was carried out. (From 9:00 till 16:00 April 29)

● Exposure of Workers

- April 30 - TEPCO summarized the result of exposure dose measurement of workers engaged in emergency work and whose external exposure dose exceeded 100 mSv at the end of March 2011.
- According to the summary, the result of exposure dose measurement (the total value of internal and external exposure and the number of personnel) was as follows: 2 persons with 200~250 mSv, 8 persons with 150~200 mSv, and 11 persons with 100~150 mSv.

For more information: NISA English Home Page
<http://www.nisa.meti.go.jp/english/index.html>

May 1, 2011

Nuclear and Industrial Safety Agency

Seismic Damage Information (the 122nd Release)
(As of 15:00 May 1, 2011)

Nuclear and Industrial Safety Agency (NISA) confirmed the current situation of Onagawa NPS, Tohoku Electric Power Co. Inc.; Fukushima Dai-ichi and Fukushima Dai-ni NPSs, Tokyo Electric Power Co. Inc. (TEPCO); Tokai Dai-ni NPS, Japan Atomic Power Co. Inc. as follows:

Major updates are as follows.

1. Nuclear Power Stations (NPSs)

● Fukushima Dai-ichi NPS

<Spraying anti-scattering agent to prevent the spread of radioactive materials>

- Full-scale implementation of spraying anti-scattering agent was carried out in the area of about 2,000m² on the south-side of the turbine building of Unit 4 using an unmanned crawler dump. (From 11:00 till 14:00 April 30)
- Full-scale implementation of spraying anti-scattering agent was carried out in the area of about 5,400 m² on the surface of the slope around the Former Main Office Building, near the gymnasium and the west-side of the shallow draft quay. (From 10:30 till 14:00 April 30)
- Removal of rubble (Amounts equivalent to 4 containers) using remote-control heavy machineries was carried out. (From 9:15 till 16:15 April 30)

For more information: NISA English Home Page
<http://www.nisa.meti.go.jp/english/index.html>

Conditions of Fukushima Dai-ichi Nuclear Power Station **Unit 1**

(As of 12:00 May 1st, 2011)

Major Events after the Earthquake 1/2

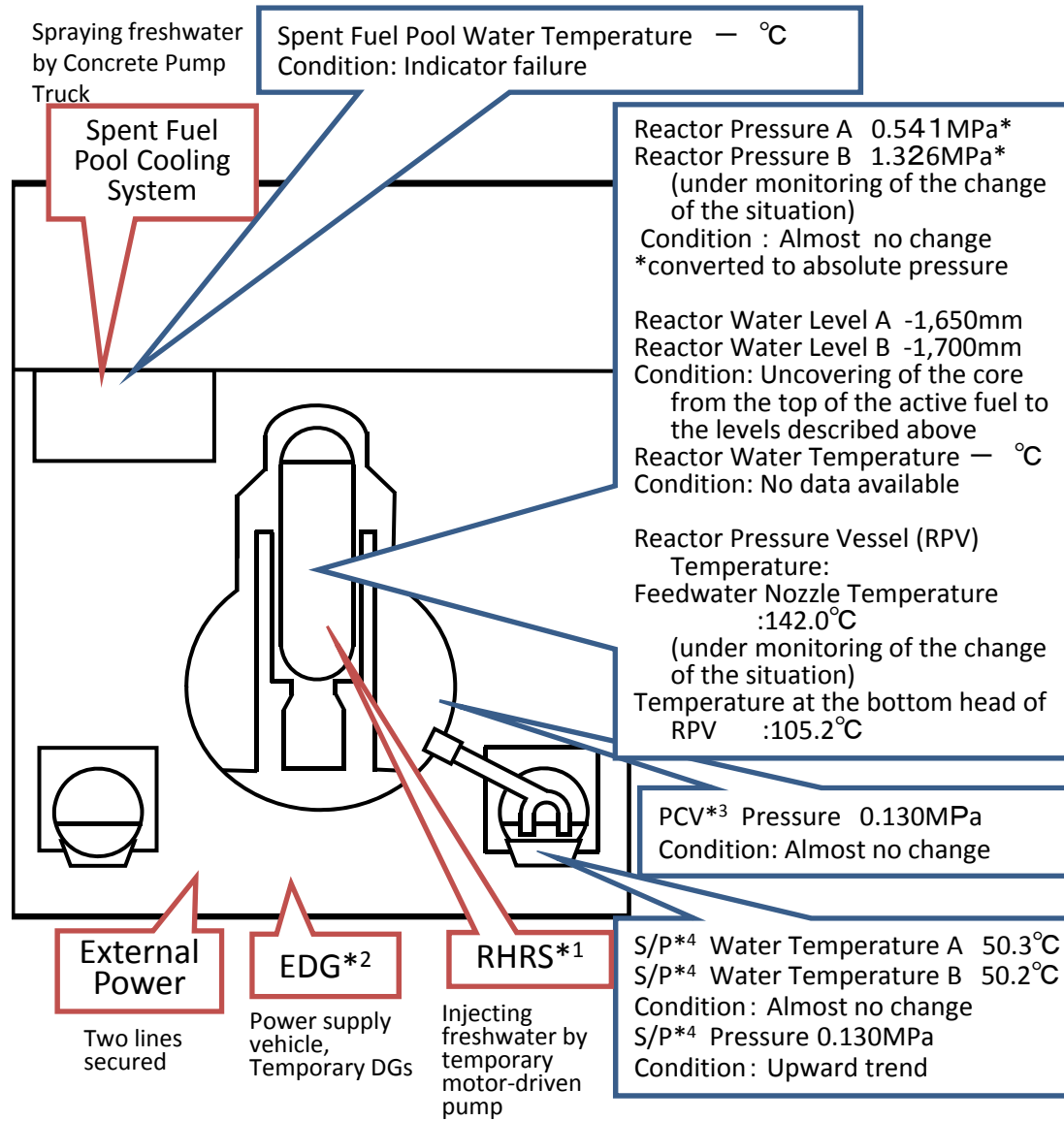

- March 11th 14:46 Under operation, Automatic shutdown by the earthquake
- March 11th 15:42 Report based on the Article 10 (Total loss of A/C power)
- March 11th 16:36 Occurrence of the Article 15 event (Inability of water injection of the Emergency Core Cooling System)
- March 12th 01:20 Occurrence of the Article 15 event (Unusual rise of the pressure in PCV)
- March 12th 10:17 Started to vent.
- March 12th 15:36 Sound of explosion
- March 12th 20:20 Started to inject seawater and borated water to the Reactor Core.
- March 23rd 02:33 The amount of injected water to the Reactor Core was increased utilizing the Feedwater Line in addition to the Fire Extinguish Line. (2m³/h →18m³/h)
- 09:00 Switched to the Feedwater Line only.(18m³/h →11m³/h)
- March 24th 11:30 Lighting in the Central Control Room was recovered.
- March 25th 15:37 Started to inject fresh water.
- March 29th 08:32 Switched to the water injection to the Reactor Core using the temporary motor-driven pump.
- March 31st 12:00 ~2nd 15:26 Started to transfer the stagnant water from the Condensate Storage Tank (CST) to the Surge Tank of Suppression Pool Water (SPT)
- March 31st 13:03~16:04 Water spray by Concrete Pump Truck (Fresh water)
- April 3rd 12:02 The power supply to the temporary motor-driven pump was switched from the temporary power supply to the external power supply.
- April 3rd 13:55 Started to transfer the water from the Condenser to CST.
- April 6th 22:30 Started the operation for the injection of nitrogen to PCV.
- April 7th 01:31 Confirmed starting the injection of nitrogen to PCV.
- April 9th 04:10 Started using highly pure nitrogen generator in the injection of nitrogen to PCV.
- April 10th 09:30 Completed transferring the water from the Condenser to CST.
- April 11th around 17:16 Loss of external power supply due to an earthquake occurred (at Hamadori in Fukushima Prefecture) and water injection to the Reactor Core and nitrogen injection to PCV were suspended.
- April 11th 17:56 External power supply was recovered.
- April 11th 18:04 Resumed injecting water to the Reactor Core.
- April 11th 23:19 Restarted operation for injecting nitrogen to PCV.
- April 11th 23:34 Confirmed starting injection of nitrogen to PCV.
- April 17th 16:00~17:30 Confirmed the situation in the reactor building using an unmanned robot.
- April 18th 11:50~12:12 Stopped the water injection into the reactor core to replace the current hose with a new one.
- April 19th 10:23 Completed the work of strengthening connection of the power supplies between Units 1-2 and Units 3-4.
- April 25th 10:57 ~18:25 For reinforcement work of the power supply, the power supply to the pump injecting water into the reactor core was temporarily switched from the external power supply to the temporary diesel generator.
- April 25th 14:10~19:10 Suspended nitrogen injection due to reinforcement work of the power supply.
- April 25th 14:44~17:38 Implemented reinforcement work of the power supply (connection of the power supplies between Units 1-2 and Units 5-6).
- April 25th 11:35~13:24(approx.) Observed the situation in the reactor building using unmanned robots.

*1 Residual Heat Removal System
 *2 Emergency Diesel Generator
 *3 Primary Containment Vessel
 *4 Suppression Pool

Current Conditions : Fresh water is being injected to the Spent Fuel Pool and the Reactor Core

Major Events after the Earthquake 2/2

April 27th 10:02 Started the operation of gradually changing the amount of water for injection to the Reactor Pressure Vessel, from about 6m³/h to the maximum of about 14m³/h. After carrying out the injection at 10m³/h, the injection rate was changed back to 6m³/h.

April 29th 11:36~14:05 Confirmed the situation in the reactor building using an unmanned robot.

Conditions of Fukushima Dai-ichi Nuclear Power Station **Unit 2**

(As of 12:00 May 1st, 2011)

Spraying freshwater by temporary motor-driven pump through existing cooling system

Major Events after the Earthquake 1/2

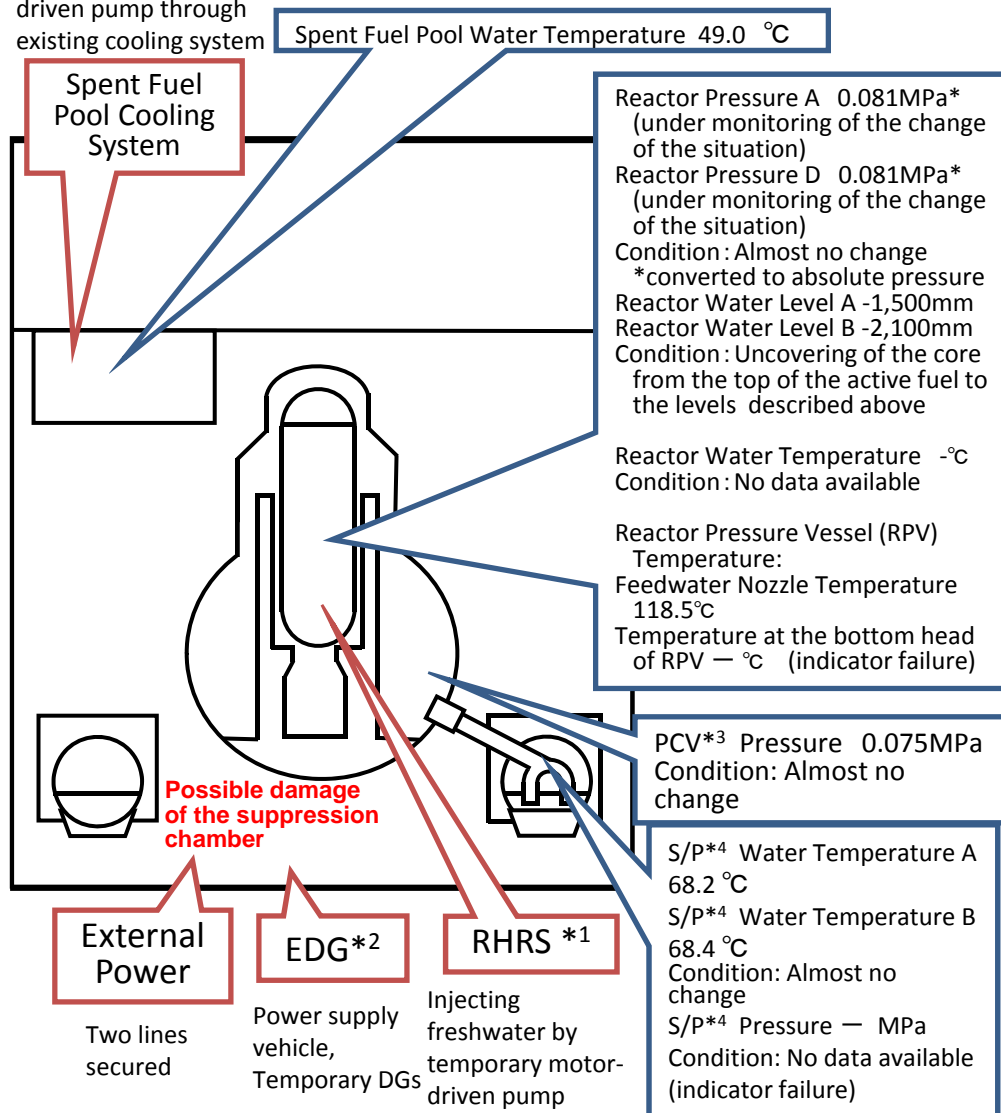

- March 11th 14:46 Under operation, Automatic shutdown by the earthquake
- March 11th 15:42 Report based on the Article 10 (Total loss of A/C power)
- March 11th 16:36 Occurrence of the Article 15 event (Inability of water injection of the Emergency Core Cooling System)
- March 13th 11:00 Started to vent.
- March 14th 13:25 Occurrence of the Article 15 event (Loss of reactor cooling functions)
- March 14th 16:34 Started to inject seawater to the Reactor Core.
- March 14th 22:50 Occurrence of the Article 15 event (Unusual rise of the pressure in PCV)
- March 15th 00:02 Started to vent.
- March 15th 06:10 Sound of explosion
- March 15th around 06:20 Possible damage of the suppression chamber
- March 20th 15:05~17:20 Approximately 40 ton seawater injection to the Spent Fuel Pool (SFP) via the Fuel Pool Cooling Line (FPC)
- March 20th 15:46 Power Center received electricity.
- March 21st 18:22 White smoke generated. The smoke died down and almost invisible at 07:11 March 22nd.
- March 22nd 16:07 Injection of around 18 tons of seawater to SFP
- March 25th 10:30~12:19 Sea water injection to SFP via FPC
- March 26th 10:10 Started to inject fresh water to the Reactor Core.
- March 26th 16:46 Lighting in the Central Control Room was recovered.
- March 27th 18:31 Switched to the water injection to the core using the temporary motor-driven pump.
- March 29th 16:30~18:25 Switched to the temporary motor-driven pump injecting fresh water to SFP.
- March 29th 16:45~1st 11:50 Transferred the water from the Condensate Storage Tank (CST) to the Surge Tank of Suppression Pool Water (SPT)
- March 30th 9:25~23:50 Confirmed malfunction of the temporary motor-driven pump injecting fresh water to SFP(9:45). Switched to the injection using the fire pump Truck, but suspended as cracks were confirmed in the hose. (12:47, 13:10) Resumed injection of fresh water(19:05)
- April 1st 14:56~17:05 Freshwater injection to SFP via FPC using the temporary motor-driven pump.
- April 2nd around 9:30 The water, of which the dose rate was at the level of more than 1,000mSv/h, was confirmed to be collected in the pit located near the Intake Channel of Unit 2. The outflow from the lateral surface of the pit into the sea was also confirmed.
- April 2nd 17:10 Started to transfer the water from the Condenser to the CST.
- April 3rd 12:12 The power supply to the temporary motor-driven pump was switched from the temporary power supply to the external power supply.
- April 3rd 13:47~14:30 20 bags of sawdust, 80 bags of high polymer absorbent and 3 bags of cutting-processed newspaper were put into the Pit for the Conduit.
- April 4th 7:08~7:11 Approximately 13kg of tracer (bath agent) was put in from the Pit for the Duct for Seawater Pipe.
- April 4th 11:05~13:37 Freshwater injection to SFP via FPC using the temporary motor-driven pump.
- April 5th 14:15 Tracer is confirmed to outflow through the permeable layer around the pit into the sea. 15:07 Started to inject coagulant.
- April 6th around 5:38 The water outflow from the lateral surface of the pit was confirmed to stopped.
- April 7th 13:29~14:34 Freshwater injection to SFP via FPC using the temporary motor-driven pump.
- April 9th 13:10 Completed transferring the water from the Condenser to CST.
- April 10th 10:37~12:38 Freshwater injection to SFP via FPC using the temporary motor-driven pump .
- April 11th around 17:16 Loss of external power supply due to an earthquake occurred (at Hamadori in Fukushima Prefecture). Water injection to the Reactor Core was suspended.
- April 11th 17:56 External power supply was recovered.
- April 11th 18:04 Resumed injecting water to the Reactor Core.

*1 Residual Heat Removal System
 *2 Emergency Diesel Generator
 *3 Primary Containment Vessel
 *4 Suppression Pool

Current Conditions: Fresh water is being injected to the Spent Fuel Pool and the Reactor Core

Major Events after the Earthquake 2/2

April 12th 19:35 ~ April 13th 17:04 Transfer from the trench of the turbine building to the Condenser.

April 13th 11:00 Suspended the transfer for checking leaks, etc.

April 13th 13:15 ~ 14:55 Freshwater injection to SFP via FPC using the temporary motor-driven pump.

April 16th 10:13 ~ 11:54 Freshwater injection to SFP via FPC using the temporary motor-driven pump. (The temporary motor-driven pump stopped at 11:39 due to an earthquake that occurred at around 11:19. SFP was confirmed to be filled to capacity through observing a rise of the water level in the Skimmer Tank.)

April 16th around 11:19 An earthquake occurred (in the southern part of Ibaraki Prefecture).

April 18th 13:42 ~ Confirmed the situation in the reactor building using an unmanned robot.

April 18th 12:13 ~ 12:37 Stopped the water injection into the reactor core to replace the current hose with a new one.

April 18th 09:30 ~ 17:40 Injected coagulant (soluble glass) into the power cable trench.

April 19th 08:00 ~ 15:30 Injected coagulant (soluble glass) into the power cable trench.

April 19th 10:08 ~ Started to transfer the stagnant water with high-level radioactivity from the trench of the turbine building to the buildings of radioactive waste treatment facilities.

April 19th 10:23 Completed the work of strengthening connection of the power supplies between Units 1-2 and Units 3-4.

April 19th 16:08 ~ 17:28 Injected freshwater to SFP via FPC using the temporary motor-driven pump.

April 22nd 15:55 ~ 17:40 Injected freshwater to SFP via FPC using the temporary motor-driven pump.

April 25th 10:12 ~ 11:18 Injected freshwater to SFP via FPC using the temporary motor-driven pump.

April 25th 10:57 ~ 18:25 For reinforcement work of the power supply, the power supply to the pump injecting water into the reactor core was temporarily switched from the external power supply to the temporary diesel generator.

April 25th 10:12 ~ 11:18 Injected freshwater to SFP via FPC using the temporary motor-driven pump.

April 25th 14:44 ~ 17:38 Implemented reinforcement work of the power supply (connection of the power supplies between Units 1-2 and Units 5-6).

April 28th 10:15 ~ 11:28 Injected freshwater to SFP via FPC using the temporary motor-driven pump.

April 29th 9:16 ~ 4/30 14:05 Suspended the transfer of stagnant water from the Turbine Building Trench of Unit 2 (Stagnant water with high-level radioactivity) to the Radioactive Waste Treatment Facility in order to carry out inspections, etc. of the transfer facilities.

→4/30 14:05 Restart the transfer

Conditions of Fukushima Dai-ichi Nuclear Power Station Unit 3 (As of 12:00 May 1st, 2011)

Major Events after the Earthquake 1/2

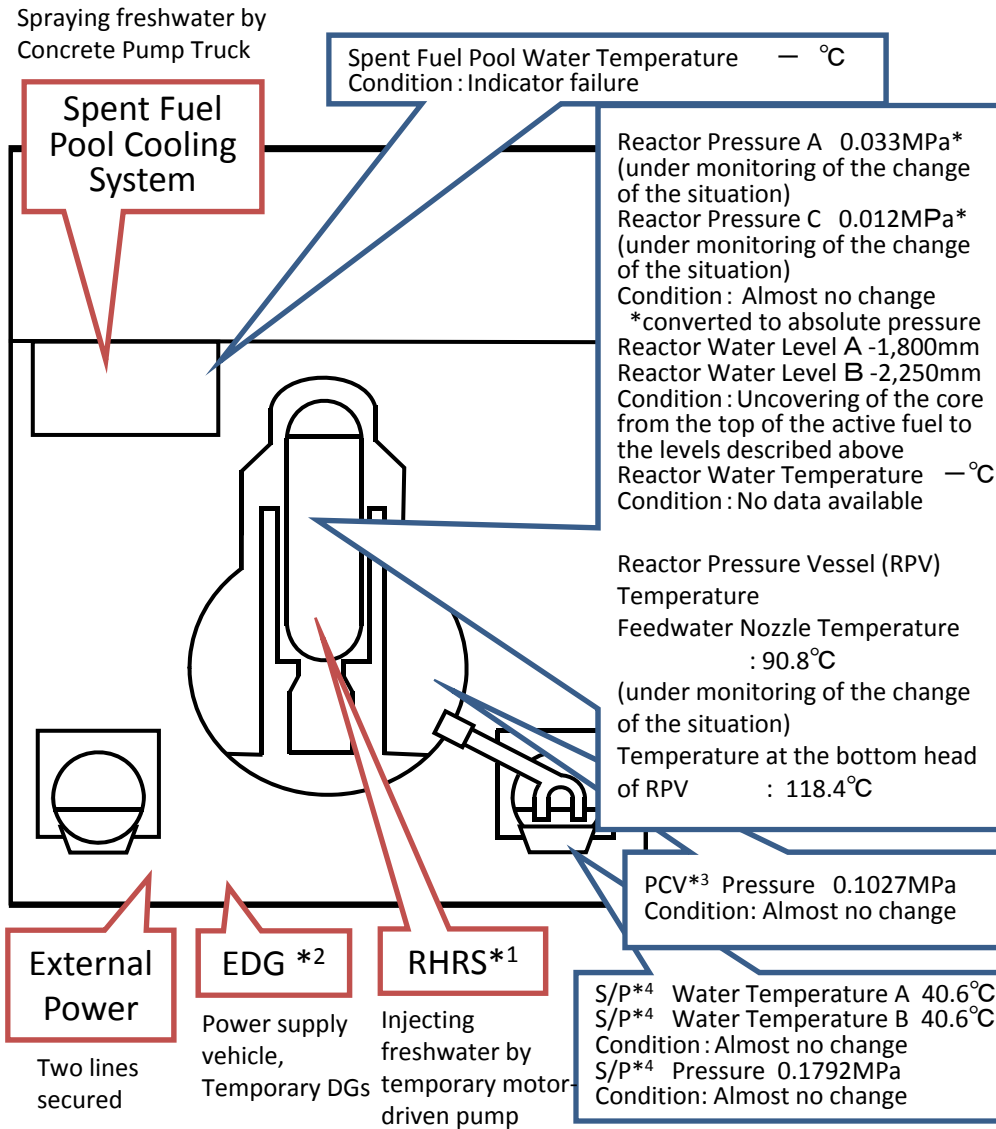

- *1 Residual Heat Removal System
- *2 Emergency Diesel Generator
- *3 Primary Containment Vessel
- *4 Suppression Pool

(Editorial committee for Nuclear Energy Handbook, Nuclear Energy Handbook)

Current Conditions: Fresh water is being injected to the Spent Fuel Pool and the Reactor Core

- March 11th 14:46 Under operation, Automatic shutdown by the earthquake
- March 11th 15:42 Report based on the Article 10 (Total loss of A/C power)
- March 13th 05:10 Occurrence of the Article 15 event (Inability of water injection of the Emergency Core Cooling System)
- March 13th 08:41 Started to vent.
- March 13th 13:12 Started to inject seawater and borated water to the Reactor Core.
- March 14th 05:20 Started to vent.
- March 14th 07:44 Occurrence of the Article 15 event (Unusual rise of the pressure in PCV)
- March 14th 11:01 Sound of explosion
- March 16th around 08:30 White smoke generated.
- March 17th 09:48 ~ 10:01 Water discharge by the helicopters of Self-Defense Force
- March 17th 19:05 ~ 19:15 Water spray from the ground by High pressure water-cannon trucks of Police
- March 17th 19:35 ~ 20:09 Water spray from the ground by fire engines of Self-Defense Force
- March 18th before 14:00 ~ 14:38 Water spray from the ground by 6 fire engines of Self-Defense Force
- March 18th ~ 14:45 Water spray from the ground by a fire engine of the US Military
- March 19th 00:30 ~ 01:10 Water spray by Hyper Rescue Unit of Tokyo Fire Department
- March 19th 14:10 ~ 20th 03:40 Water spray by Hyper Rescue Unit of Tokyo Fire Department
- March 20th 11:00 Pressure of PCV rose(320kPa).Afterward fell.
- March 20th 21:36 ~ 21st 03:58 Water spray by Hyper Rescue Unit of Tokyo Fire Department
- March 21st around 15:55 Grayish smoke generated and was confirmed to be died down at 17:55.
- March 22nd 15:10 ~ 16:00 Water spray by Hyper Rescue Unit of Tokyo Fire Department and Osaka City Fire Bureau.
- March 22nd 22:46 Lighting in the Central Control Room was recovered.
- March 23rd 11:03 ~ 13:20 Injection of about 35 ton of sea water to the Spent Fuel Pool (SFP) via the Fuel Pool Cooling Line (FPC)
- March 23rd around 16:20 Black smoke generated and was confirmed to died down at around 23:30 and 24th 04:50.
- March 24th 05:35 ~ 16:05 Injection of around 120 ton of sea water to SFP via FPC
- March 25th 13:28 ~ 16:00 Water spray by Kawasaki City Fire Bureau supported by Tokyo Fire Department
- March 25th 18:02 Started fresh water injection to the core.
- March 27th 12:34 ~ 14:36 Water spray by Concrete Pump Truck
- March 28th 17:40 ~ 31st around 8:40 Transferring the water from the Condensate Storage Tank (CST) to the Surge Tank of Suppression Pool Water (SPT)
- March 28th 20:30 Switched to the water injection to the core using a temporary motor-driven pump.
- April 3rd 12:18 The power supply to the temporary motor-driven pump was switched from the temporary power supply to the external power supply.
- April 11th around 17:16 Loss of external power supply of Unit 1 and 2 due to an earthquake occurred (at Hamadori in Fukushima Prefecture) and water injection to the Reactor Core was suspended.
- April 11th 18:04 External power supply of Units 1 and 2 recovered (April 11th 17:56). Resumed injecting water to the Reactor Core.
- April 17th 11:30 ~ 14:00 Confirmed the situation in the reactor building using unmanned robot.
- April 18th 12:38 ~ 13:05 Stopped the water injection into the reactor core to replace the current hose with a new one

Major Events after the Earthquake 2/2

April 19th 10:23 Completed the work of strengthening connection of the power supplies between Units 1-2 and Units 3-4.

April 22nd 13:40~14:00 Tentatively Injected freshwater to SFP via the Fuel Pool Coolant Purification Line.

April 25th 10:57~18:25 For reinforcement work of the power supply, the power supply to the pump injecting water into the reactor core was temporarily switched from the external power supply to the temporary diesel generator.

April 30th 11:34 Completed reinforcement work of the power supply both Units 3, 4). (Increasing the voltage from 6.6kv to 66kv)

<Water spray by Concrete Pump Truck (Fresh water)>

March 29th 14:17~18:18, March 31st 16:30~19:33, April 2nd 09:52~12:54, April 4th 17:03~19:19, April 7th 06:53 ~ 08:53, April 8th 17:06~20:00, April 10th 17:15~19:15, April 12th 16:26~17:16, April 14th 15:56~16:32, April 18th 14:17 ~15:02, April 22nd 14:19~15:40, April 26th 12:25~14:02

Conditions of Fukushima Dai-ichi Nuclear Power Station **Unit 4** (As of 12:00 May 1st, 2011)

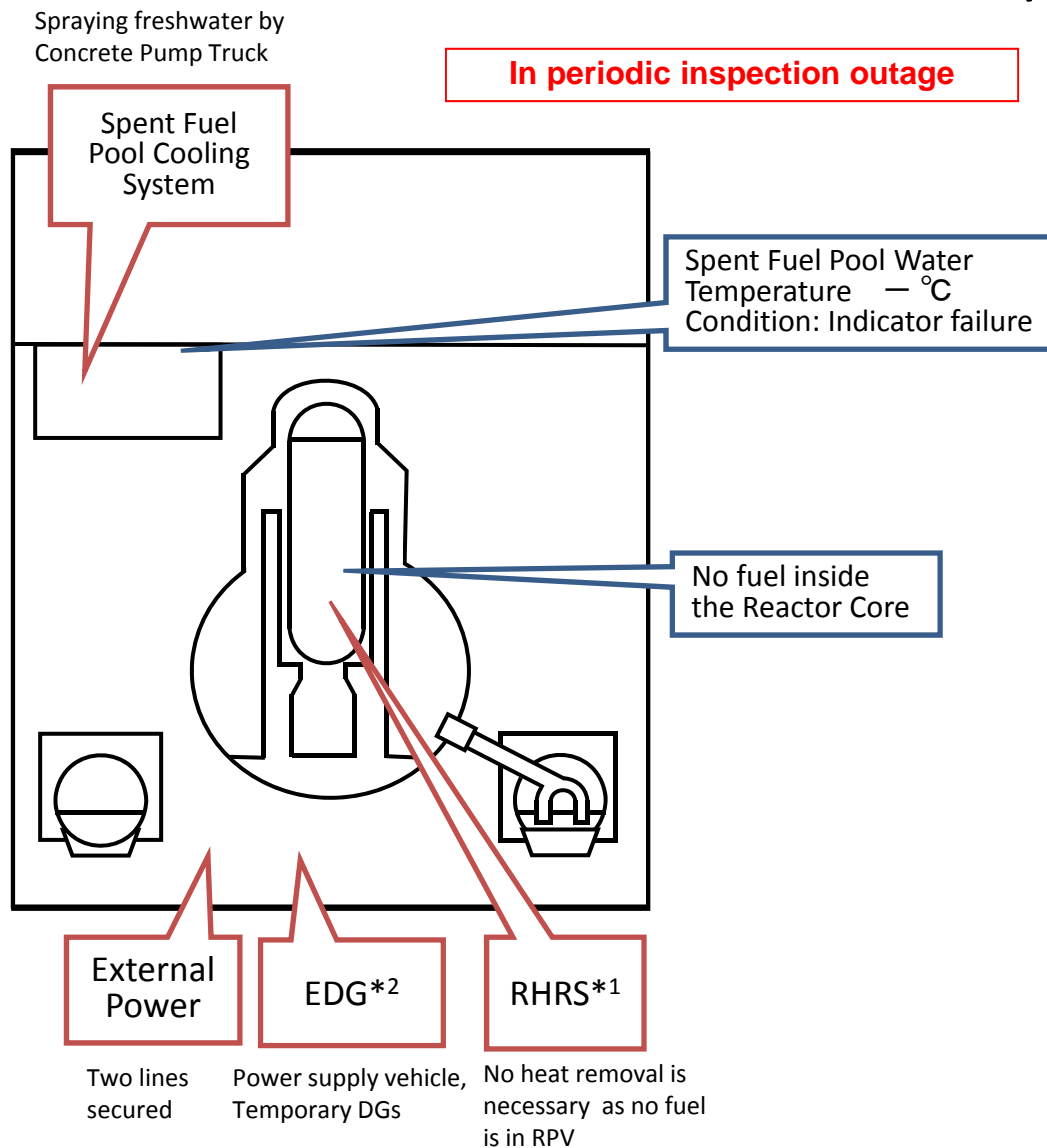

Major Events after the Earthquake

In periodic inspection outage when the earthquake occurred

March 14th 04:08 Water temperature in the Spent Fuel Pool (SFP), 84°C

March 15th 06:14 Confirmed the partial damage of wall in the 4th floor.

March 15th 09:38 Fire occurred in the 3rd floor. (12:25 extinguished)

March 16th 05:45 Fire occurred. TEPCO couldn't confirm any fire on the ground. (06:15)

March 20th 08:21~09:40 Water spray over SFP by Self-Defense Force

March 20th around 18:30~19:46 Water spray over SFP by Self-Defense Force

March 21st 06:37~08:41 Water spray over SFP by Self-Defense Force

March 21st around 15:00 Work for laying cable to Power Center was completed.

March 22nd 10:35 Power Center received electricity.

<Water spray by Concrete Pump Truck (Seawater)>

March 22nd 17:17~20:32, March 23rd 10:00~13:02, March 24th 14:36~17:30, March 25th 19:05~22:07, March 27th 16:55~19:25

March 25th 06:05~10:20 Sea water injection to SFP via the Fuel Pool Cooling Line (FPC)

March 29th 11:50 Lighting in the Central Control Room was recovered.

April 11th around 17:16 An earthquake occurred (at Hamadori in Fukushima Prefecture).

April 12th 12:00~13:04 Sampled the water in SFP.

April 19th 10:23 Completed the work of strengthening connection of the power supplies between Units 1-2 and Units 3-4.

April 22nd Measured the water level of SFP by a gauge hung on Concrete Pump Truck (62m class).

April 30th 11:34 Completed reinforcement work of the power supply both Units 3, 4). (Increasing the voltage from 6.6kv to 66kv)

< Water spray by Concrete Pump Truck (Fresh water)>

March 30th 14:04~18:33, April 1st 08:28~14:14, April 3rd 17:14~22:16, April 5th 17:35~18:22, April 7th 18:23~19:40, April 9th 17:07~19:24, April 13th 0:30~6:57, April 15th 14:30~18:29, April 17th 17:39~21:22, April 19th 10:17~11:35, April 20th 17:08~20:31, April 21st 17:14~21:20, April 22nd 17:52~23:53, April 23rd 12:30~16:44, April 24th 12:25~17:07, April 25th 18:15~April 26th 0:26, April 26th 16:50~20:35, April 27th 12:18~15:15

**Current Conditions: No fuel is in RPV*3.
Fresh water is being injected to the Spent Fuel Pool.**

(Editorial committee for Nuclear Energy Handbook, Nuclear Energy Handbook)

*1 Residual Heat Removal System

*2 Emergency Diesel Generator

*3 Reactor Pressure Vessel

Conditions of Fukushima Dai-ichi Nuclear Power Station **Unit 5**

(As of 12:00 May 1st, 2011)

In periodic inspection outage

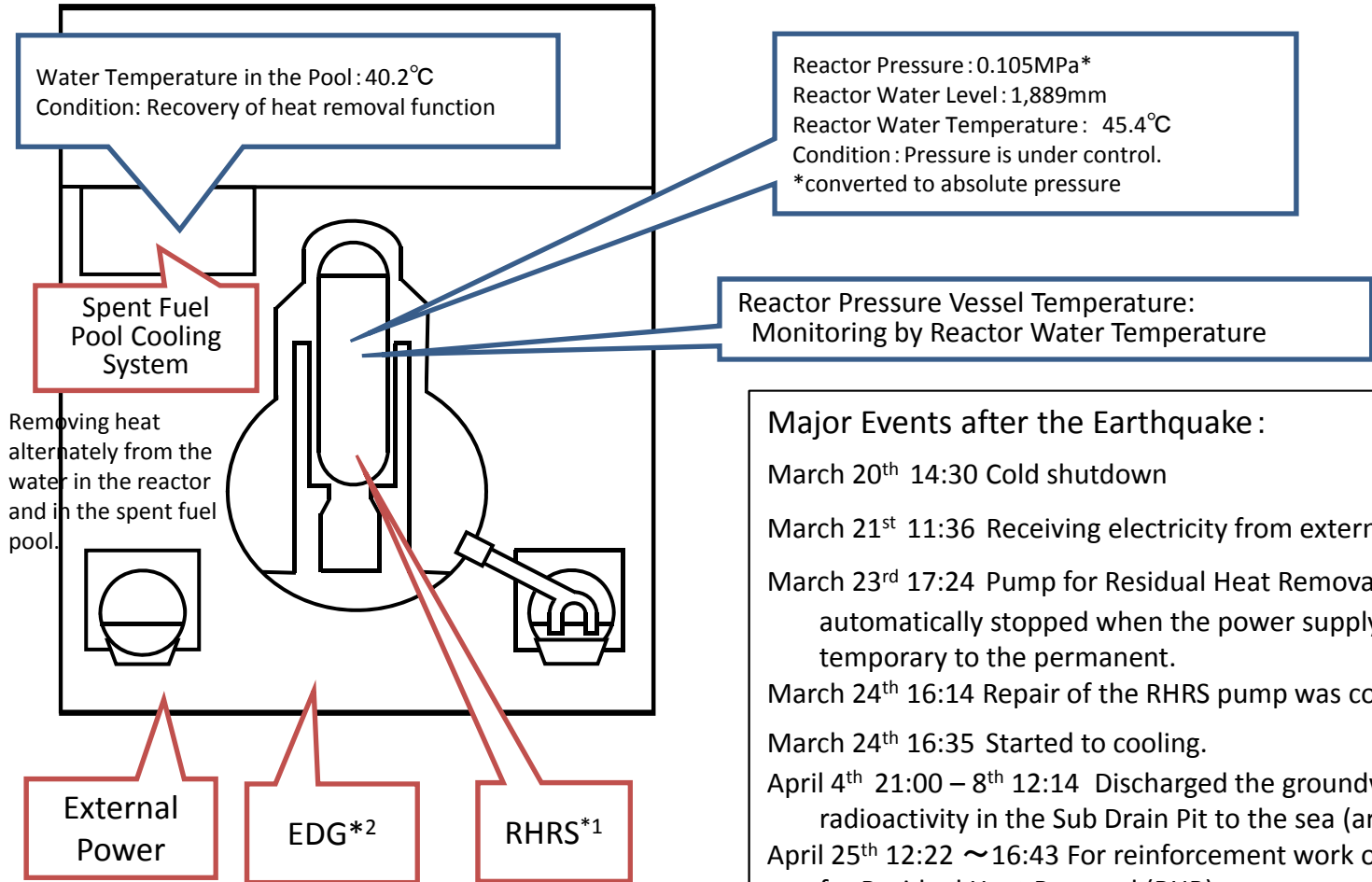

Major Events after the Earthquake :

- March 20th 14:30 Cold shutdown
- March 21st 11:36 Receiving electricity from external power supply
- March 23rd 17:24 Pump for Residual Heat Removal Seawater System (RHR) was automatically stopped when the power supply was switched from the temporary to the permanent.
- March 24th 16:14 Repair of the RHR pump was completed.
- March 24th 16:35 Started to cooling.
- April 4th 21:00 – 8th 12:14 Discharged the groundwater with low-level radioactivity in the Sub Drain Pit to the sea (around 950 ton).
- April 25th 12:22 ~ 16:43 For reinforcement work of the power supply, the pump for Residual Heat Removal (RHR) was temporarily stopped.
- April 25th 14:44 ~ 17:38 Implemented reinforcement work of the power supply (connection of the power supplies between Units 1-2 and Units 5-6).

*1 Residual Heat Removal System

*2 Emergency Diesel Generator

Conditions of Fukushima Dai-ichi Nuclear Power Station **Unit 6**

(As of 12:00 May 1st, 2011)

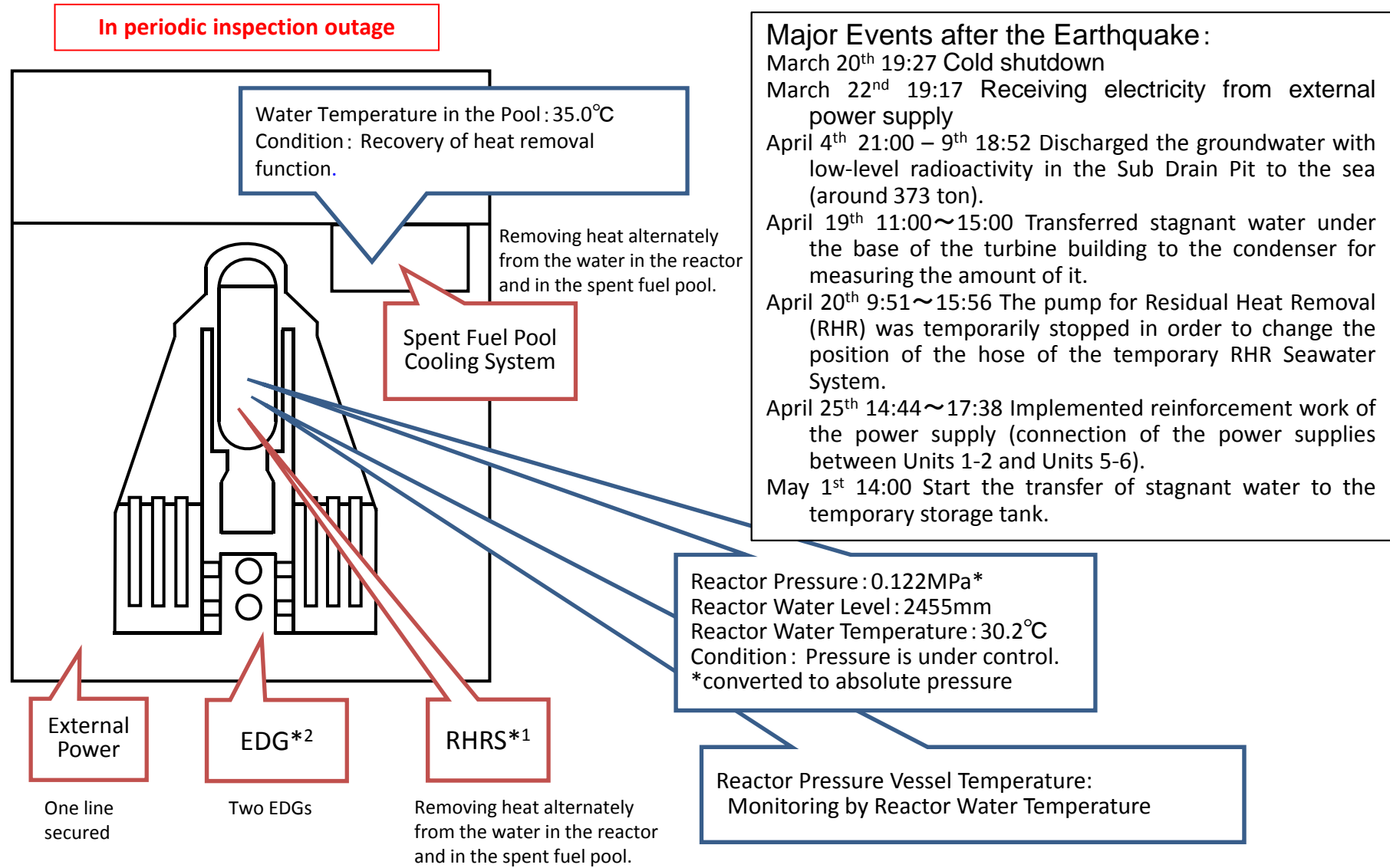

Major Events after the Earthquake :
 March 20th 19:27 Cold shutdown
 March 22nd 19:17 Receiving electricity from external power supply
 April 4th 21:00 – 9th 18:52 Discharged the groundwater with low-level radioactivity in the Sub Drain Pit to the sea (around 373 ton).
 April 19th 11:00~15:00 Transferred stagnant water under the base of the turbine building to the condenser for measuring the amount of it.
 April 20th 9:51~15:56 The pump for Residual Heat Removal (RHR) was temporarily stopped in order to change the position of the hose of the temporary RHR Seawater System.
 April 25th 14:44~17:38 Implemented reinforcement work of the power supply (connection of the power supplies between Units 1-2 and Units 5-6).
 May 1st 14:00 Start the transfer of stagnant water to the temporary storage tank.

*1 Residual Heat Removal System

*2 Emergency Diesel Generator