

April 14, 2011

Nuclear and Industrial Safety Agency

Seismic Damage Information (the 93rd Release)

(As of 15:00 April 14th, 2011)

Nuclear and Industrial Safety Agency (NISA) confirmed the current situation of Onagawa NPS, Tohoku Electric Power Co. Inc.; Fukushima Dai-ichi and Fukushima Dai-ni NPSs, Tokyo Electric Power Co. Inc. (TEPCO); Tokai Dai-ni NPS, Japan Atomic Power Co. Inc. as follows:

Major updates are as follows.

1. Nuclear Power Stations (NPSs)

● Fukushima Dai-ichi NPS

- The silt fences to prevent the spread of the contaminated water were installed at the Curtain Wall and in front of the Screen of Units 1 and 2. (12:20 April 14th)
- In order to cool the Spent Fuel Pool of Unit 3, fresh water spray using Concrete Pump Truck (50t/h) was started. (15:56 April 14th)
- Videotaping using a wireless helicopter was carried out in order to grasp the situations of reactor buildings for Units 3 and 4. (From 10:17 till 12:25 April 14th)

(Attached sheet)

1. The state of operation at NPS (Number of automatic shutdown units: 10)

- Fukushima Dai-ichi NPS, TEPCO

(Okuma Town and Futaba Town, Futaba County, Fukushima Prefecture)

(1) The state of operation

- Unit 1 (460MWe): automatic shutdown
- Unit 2 (784MWe): automatic shutdown
- Unit 3 (784MWe): automatic shutdown
- Unit 4 (784MWe): in periodic inspection outage
- Unit 5 (784MWe): in periodic inspection outage, cold shutdown at 14:30 March 20th
- Unit 6 (1,100MWe): in periodic inspection outage, cold shutdown at 19:27 March 20th

(2) Major Plant Parameters (As of 08:00 April 14th)

	Unit 1	Unit 2	Unit 3	Unit 4	Unit 5	Unit 6
Reactor Pressure*1 [MPa]	0.521(A) 1.041(B)	0.085(A) 0.080(D)	0.084(A) 0.018(C)	—	0.104	0.111
CV Pressure (D/W) [kPa]	190	95	104.7	—	—	—
Reactor Water Level*2 [mm]	-1,600(A) -1,600(B)	-1,500(A) Not available(B)	-1,800(A) -2,250(B)	—	1,842	2,268
Suppression Pool Water Temperature (S/C) [°C]	—	—	—	—	—	—
Suppression Pool Pressure (S/C) [kPa]	165	Indicator Failure	167.3	—	—	—
Spent Fuel Pool Water Temperature [°C]	Indicator Failure	71.0	Indicator Failure	Indicator Failure	36.1	30.0
Time of Measurement	06:00 April 14th	06:00 April 14th	06:05 April 14th	April 14th	08:00 April 14th	08:00 April 14th

*1: Converted from reading value to absolute pressure

*2: Distance from the top of fuel

(3) Situation of Each Unit

<Unit 1>

- TEPCO reported to NISA the event (Inability of water injection of the Emergency Core Cooling System) falling under the Article 15 of the Act on Special Measures Concerning Nuclear Emergency Preparedness. (16:36 March 11th)
- Started to vent (10:17 March 12th)
- Seawater injection to the Reactor Pressure Vessel (RPV) via the Fire Extinguish Line was started. (20:20 March 12th)
→Temporary interruption of the injection (01:10 March 14th)
- The sound of explosion in Unit 1 occurred. (15:36 March 12th)
- The amount of injected water to the Reactor Core was increased by utilizing the Feedwater Line in addition to the Fire Extinguish Line. (2m³/h→18m³/h). (02:33 March 23rd) Later, it was switched to the Feedwater Line only (around 11m³/h). (09:00 March 23rd)
- Lighting in the Central Operation Room was recovered. (11:30 March 24th)
- Fresh water injection to RPV was started. (15:37 March 25)
- As the result of concentration measurement in the stagnant water on the basement floor of the turbine building, 2.1×10^5 Bq/cm³ of ¹³¹I (Iodine) and 1.8×10^6 Bq/cm³ of ¹³⁷Cs (Caesium) were detected as major radioactive nuclides.
- The pump for the fresh water injection to RPV was switched from the Fire Pump Truck to the temporary motor-driven pump. (08:32 March 29th.)
- The Stagnant water on the basement floor of the turbine building was started to be transferred to the Condenser around 17:00 March 24. As the Condenser was confirmed to be almost filled with water, pumping out of the water to the Condenser was stopped. (07:30 March 29th) In order to prepare to transfer the stagnant water on the basement floor of the turbine building to the Condenser, the water in the Condensate Storage Tank started to be transferred to the Surge Tank of Suppression Pool Water (A) (12:00 March 31th), after switching the place where the water was to be transferred to the Surge Tank of

Suppression Pool Water (B) (15:25 March 31th), the transfer was resumed and finished. (15:26 April 2nd)

- Water spray of around 90t (fresh water) over the Spent Fuel Pool using Concrete Pump Truck was carried out. (From 13:03 till 16:04 March 31st) A test water spray using Concrete Pump Truck was carried out in order to confirm the appropriate position for water spray. (From 17:16 till 17:19 April 2nd)
- Lighting in the turbine building was partially turned on. (April 2nd)
- In order to switch the power supply to the motor-driven pump injecting fresh water to RPV from the temporary power supply to the external power supply, the injection to the reactor was temporarily carried out using the Fire Pump Truck. (10:42 to 11:52 April 3rd)
- The power supply for the fresh water injection to RPV was switched to the external power supply. (12:12 April 3rd)
- In order to prepare to transfer the stagnant water on the basement floor of the turbine building to the Condenser, the transfer of the water in the Condenser to the Condensate Storage Tank was started. (13:55 April 3rd)
- Aiming at reducing the possibility of hydrogen combustion in the Primary Containment Vessel (PCV), the operations for the injection of nitrogen to PCV were started. (22:30 April 6th)
- The start of nitrogen injection to PCV was confirmed. (01:31 April 7th)
- The nitrogen injection to PCV was switched to the generator of high purity nitrogen. (04:10 April 9th)
- The transfer of the water in the Condenser to the Condensate Storage Tank was completed. (09:30 April 10th)
- Due to the occurrence of earthquake, the external power supply was lost, and the fresh water injection to RPV and the nitrogen injection to PVC were suspended. (Around 17:16 April 11th)
- The external power supply was recovered. (17:56 April 11th)
- Fresh water injection to RPV was resumed. (18:04 April 11th)
- The nitrogen injection to PCV was started. (23:34 April 11th)
- White smoke was not confirmed to generate. (As of 06:30 April 14th)
- Fresh water injection to RPV is being carried out. (As of 15:30 April 14th)

<Unit 2>

- TEPCO reported to NISA the event (Inability of water injection of the Emergency Core Cooling System) falling under the Article 15 of the Act on Special Measures Concerning Nuclear Emergency Preparedness. (16:36 March 11th)
- Started to vent (11:00 March 13th)
- The Blow-out Panel of reactor building was opened due to the explosion in the reactor building of Unit 3. (After 11:00 March 14th)
- Reactor water level tended to decrease. (13:18 March 14th) TEPCO reported to NISA the event (Loss of reactor cooling functions) falling under the Article 15 of the Act on Special Measures Concerning Nuclear Emergency Preparedness. (13:49 March 14th)
- Seawater injection to RPV via the Fire Extinguish line was started. (16:34 March 14th)
- Water level in RPV tended to decrease. (22:50 March 14th)
- Started to vent (0:02 March 15th)
- A sound of explosion was made in Unit 2. As the pressure in Suppression Pool (Suppression Chamber) decreased (06:10 March 15th), there was a possibility that an incident occurred in the Chamber. (About 06:20 March 15th)
- Electric power receiving at the emergency power source transformer from the external transmission line was completed. The work for laying the electric cable from the facility to the load side was carried out. (13:30 March 19th)
- Seawater injection of 40t to the Spent Fuel Pool was started. (From 15:05 till 17:20 March 20th)
- Power Center received electricity (15:46 March 20th)
- White smoke generated. (18:22 March 21st)
- White smoke was died down and almost invisible. (As of 07:11 March 22nd)
- Seawater injection of 18t to the Spent Fuel Pool was carried out. (From 16:07 till 17:01 March 22nd)
- Seawater injection to the Spent Fuel Pool via the Spent Fuel Pool Cooling Line was carried out. (From 10:30 till 12:19 March 25th)
- Fresh water injection to RPV was started. (10:10 March 26th)
- Lighting of Central Operation Room was recovered (16:46 March 26th)

- The pump for the fresh water injection to RPV was switched from the Fire Pump Truck to the temporary motor-driven pump.(18:31 March 27th)
- Regarding the result of the concentration measurement in the stagnant water on the basement floor of the turbine building of Unit 2 of Fukushima Dai-ichi NPS announced by TEPCO on 27 March, TEPCO reported to NISA that as the result of analysis and evaluation through re-sampling, judging the measured value of ^{134}I (Iodine) was wrong, the concentrations of gamma nuclides including ^{134}I (Iodine) were less than the detection limit. (00:07 March 28).
- Seawater injection to the Spent Fuel Pool using the Fire Pump Truck was switched to the fresh water injection using the temporary motor-driven pump. (From 16:30 till 18:25 March 29th)
- As the malfunction of the temporary motor-driven pump, which had been injecting to the Spent Fuel Pool since 09:25 March 30th, was confirmed at 09:45 March 30th, the injection pump was switched to the Fire Pump Truck. However, because cracks were confirmed in the hose (12:47 and 13:10 March 30th), the injection was suspended. Fresh water injection was resumed. (From 19:05 till 23:50 March 30th)
- Fresh water injection of around 70t to the Spent Fuel Pool via the Spent Fuel Pool Cooling Line using the temporary motor-driven pump was carried out. (From 14:56 till 17:05 April 1st)
- In order to prepare to transfer the stagnant water on the basement floor of the turbine building to the Condenser, the water in the Condensate Storage Tank was transferred to the Surge Tank of Suppression Pool Water. (From 16:45 March 29th till 11:50 April 1st)
- The water, of which the dose rate was at the level of more than 1,000 mSv/h, was confirmed to be collected in the pit (a vertical portion of an underground structure) for laying electric cables, located near the Intake Channel. In addition, the outflow from the crack with a length of around 20 cm in the concrete portion of the lateral surface of the pit into the sea was confirmed. (Around 09:30 April 2nd) In order to stop the outflow, concrete was poured into the pit. (16:25, 19:02 April 2nd)
- In order to prepare to transfer the stagnant water on the basement floor of the turbine building to the Condenser, the transfer of the water in the Condenser to the Condensate Storage Tank was started. (17:10 April

2nd)

- The cameras for monitoring the water levels in the vertical part of the trench outside of the turbine building and on the basement floor of the turbine building were installed. (April 2nd)
- Lighting in the turbine building was partially turned on. (April 2nd)
- In order to switch the power supply to the motor-driven pump injecting fresh water to RPV from the temporary power supply to the external power supply, the injection to the reactor was temporarily carried out using the Fire Pump Truck. (From 10:22 till 12:06 April 3rd)
- The power supply for the fresh water injection to RPV was switched to the external power supply. (12:12 April 3rd)
- As the measure to prevent the outflow of the water accumulated in the Pits for Conduit in the area around the Inlet Bar Screen, the upper part of the Power Cable Trench for power source at Intake Channel was crushed and 20 bags of sawdust (3 kg/bag), 80 bags of high polymer absorbent (100 g/bag) and 3 bags of cutting-processed newspaper (Large garbage bag) were put inside. (From 13:47 till 14:30 April 3rd)
- Approximately 13kg of tracer (milk white bath agent) was put in from the Pit for the Duct for Seawater Pipe. (From 07:08 till 07:11 April 4th)
- Fresh water injection (Around 70t) to the Spent Fuel Pool via the Spent Fuel Pool Cooling Line using the temporary motor-driven pump was carried out. (From 11:05 till 13:37 April 4th)
- The tracer solution was put in from the two holes dug around the Pit for the Conduit near the Inlet Bar Screen of Unit 2 and was confirmed to be flowed out from the crack to the sea. (14:15 April 5th) The coagulant (soluble glass) started to be injected from the holes around the Pit in order to prevent the outflowing of the water. (15:07 April 5th) The outflow of the water was confirmed to stop. (Around 05:38 April 6th) In addition, it was confirmed that the water level in the turbine building did not rise. Furthermore, the measurements to stop water by means of rubber board and jig (prop) were implemented at the outflowing point. (Finished at 13: 15 April 6th)
- One more pump for the transfer of the water in the Condenser to the Condensate Storage Tank was installed. (Two pumps in total: 30 m³/h) (Around 15:40 April 5th)
- Fresh water injection (Around 36t) to the Spent Fuel Pool via the Spent

- Fuel Pool Cooling Line was carried out. (From 13:39 till 14:34 April 7th)
- The transfer of the water in the Condenser to the Condensate Storage Tank was completed. (13:10 April 9th)
 - Fresh water injection (Around 60t) to the Spent Fuel Pool via the Spent Fuel Pool Cooling Line was carried out. (From 10:37 till 12:38 April 10th)
 - Due to the occurrence of earthquake, the external power supply was lost, and the fresh water injection to RPV was suspended. (Around 17:16 April 11th)
 - The external power supply was recovered. (17:56 April 11th)
 - Fresh water injection to RPV was resumed. (18:04 April 11th)
 - The stagnant water in the trench of the turbine building was started to be transferred to the Hot Well of the Condenser using a submersible pump (19:35 April 12th) Thereafter it was confirmed that no leakage was found, the transfer of stagnant water resumed from 15:02 April 13th and was stopped 17:04 April 13th. The amount of transfer was about 660t.
 - Fresh water injection (Around 60t) to the Spent Fuel Pool via the Spent Fuel Cooling Line was carried out. (From 13:15 till 14:55 April 13th)
 - White smoke was confirmed to generate continuously. (As of 06:30 April 14th)
 - Fresh water injection to RPV is being carried out. (As of 15:30 April 14th)

<Unit 3>

- TEPCO reported to NISA the event (Inability of water injection of the Emergency Core Cooling System) falling under the Article 15 of the Act on Special Measures Concerning Nuclear Emergency Preparedness. (05:10 March 13th)
- Started to vent (08:41 March 13th)
- Fresh water started to be injected to RPV via the Fire Extinguish Line. (11:55 March 13th)
- Seawater started to be injected to RPV via the Fire Extinguish Line. (13:12 March 13th)
- Seawater injection for Units 1 and 3 was suspended due to the lack of seawater in pit. (01:10 March 14th)

- Seawater injection to RPV for Unit 3 was resumed. (03:20 March 14th)
- Started to vent. (05:20 March 14th)
- PCV rose unusually. (07:44 March 14th) TEPCO reported to NISA on the event falling under the Article 15 of the Act on Special Measures Concerning Nuclear Emergency Preparedness. (7:52 March 14th)
- The explosion like Unit 1 occurred around the reactor building (11:01 March 14th)
- The white smoke like steam generated. (08:30 March 16th)
- Because of the possibility that PCV was damaged, the workers evacuated from the main control room (common control room). (10:45 March 16th) Thereafter the operators returned to the room and resumed the operation of water injection. (11:30 March 16th)
- Seawater was discharged 4 times to Unit 3 by the helicopters of the Self-Defence Force. (9:48, 9:52, 9:58 and 10:01 March 17th)
- The riot police arrived at the site for the water spray from the ground. (16:10 March 17th)
- The Self-Defence Force started the water spray using a fire engine. (19:35 March 17th)
- The water spray from the ground was carried out by the riot police. (From 19:05 till 19:13 March 17th)
- The water spray from the ground was carried out by the Self-Defense Force using 5 fire engines. (19:35, 19:45, 19:53, 20:00 and 20:07 March 17th)
- The water spray from the ground using 6 fire engines (6 tons of water spray per engine) was carried out by the Self-Defence Force. (From before 14:00 till 14:38 March 18th)
- The water spray from the ground using a fire engine provided by the US Military was carried out. (Finished at 14:45 March 18th)
- Hyper Rescue Unit of Tokyo Fire Department carried out the water spray. (Finished at 03:40 March 20th)
- The pressure in PCV rose (320 kPa at 11:00 March 20th). Preparation to lower the pressure was carried out. Judging from the situation, immediate pressure relief was not required. Monitoring the pressure continues. (120 kPa at 12:15 March 21st)
- On-site survey for leading electric cable (From 11:00 till 16:00 March 20th)

- Water spray over the Spent Fuel Pool of Unit 3 by Hyper Rescue Unit of Tokyo Fire Department was carried out (From 21:30 March 20th till 03:58 March 21st).
- Grayish smoke generated. (Around 15:55 March 21st)
- The smoke was confirmed to be died down. (17:55 March 21st)
- Grayish smoke changed to be whitish and seems to be ceasing. (As of 07:11 March 22nd)
- Water spray (Around 180t) by Tokyo Fire Department and Osaka City Fire Bureau was carried out. (From 15:10 till 16:00 March 22nd)
- Lighting was recovered in the Central Operation Room. (22:43 March 22nd)
- Seawater injection of 35t to the Spent Fuel Pool via the Fuel Pool Cooling Line was carried out. (From 11:03 till 13:20 March 23rd) Around 120t of seawater was injected. (From around 5:35 till around 16:05 March 24th)
- Slightly blackish smoke generated from the reactor building. (Around 16:20 March 23rd) Around 23:30 March 23rd and around 4:50 March 24th, it was reported that the smoke seemed to cease.
- As the results of the survey of the stagnant water, into which workers who were laying electric cable on the ground floor and the basement floor of the turbine building walked, the dose rate on the water surface was around 400mSv/h, and as the result of gamma-ray analysis of the sampling water, the totaled concentration of each nuclide of the sampling water was around 3.9×10^6 Bq/cm³.
- Water spray by Kawasaki City Fire Bureau supported by Tokyo Fire Department was carried out. (From 13:28 till 16:00 March 25th)
- Fresh water injection to RPV was started. (18:02 March 25th)
- Seawater spray of around 100t using Concrete Pump Truck (50t/h) was carried out. (From 12:34 till 14:36 March 27th)
- In order to prepare to transfer the stagnant water on the basement floor of the turbine building to the Condenser, the water in the Condensate Storage Tank is being transferred to the Surge Tank of Suppression Pool Water. (From 17:40 March 28th till around 8:40 March 31st)
- The pump for the fresh water injection to RPV was switched from the Fire Pump Truck to the temporary motor-driven pump. (20:30 March 28th)

- Fresh water spray of around 100t using Concrete Pump Truck (50t/h) was carried out. (From 14:17 till 18:18 March 29th)
- Fresh water spray of around 105t using Concrete Pump Truck (50t/h) was carried out. (From 16:30 till 19:33 March 31st)
- Fresh water spray of around 75t using Concrete Pump Truck (50t/h) was carried out. (From 09:52 till 12:54 April 2nd)
- Lighting in the turbine building was partially turned on. (April 2nd)
- The camera for monitoring the water level in the vertical part of the trench outside of the turbine building was installed. (April 2nd)
- In order to switch the power supply to the motor-driven pump injecting fresh water to RPV from the temporary power supply to the external power supply, the injection to the reactor was temporarily carried out using the Fire Pump Truck. (From 10:03 till 12:16 April 3rd)
- The power supply for the fresh water injection to RPV was switched to the external power supply. (12:18 April 3rd)
- Fresh water spray of around 70t using Concrete Pump Truck (50t/h) was carried out. (From 17:03 till 19:19 April 4th)
- Fresh water spray of around 70t using Concrete Pump Truck (50t/h) was carried out. (From 06:53 till 08:53 April 7th)
- Fresh water spray of around 75t using Concrete Pump Truck (50t/h) was carried out. (From 17:06 till 20:00 April 8th)
- Fresh water spray of around 80t using Concrete Pump Truck (50t/h) was carried out. (From 17:15 till 19:15 April 10th)
- Due to the occurrence of earthquake, the external power supply for Units 1 and 2 was lost, and the fresh water injection to RPV was suspended. (Around 17:16 April 11th)
- Because the external power supply for Units 1 and 2 was recovered (17:56 April 11th), fresh water injection to RPV was resumed. (18:04 April 11th)
- Fresh water spray of around 35t using Concrete Pump Truck (50t/h) was carried out (From 16:26 till 17:16 April 12th)
- White smoke was confirmed to generate continuously (As of 06:30 April 14th)
- In order to cool the Spent Fuel Pool, fresh water spray using Concrete Pump Truck (50t/h) was started. (15:56 April 14th)

- Fresh water injection to RPV is being carried out. (As of 15:30 April 14th)

<Unit 4>

- Because of the replacement work of the Shroud of RPV, no fuel was inside the RPV.
- The temperature of water in the Spent Fuel Pool had increased. (84 °C at 04:08 March 14th)
- It was confirmed that a part of wall in the operation area was damaged. (06:14 March 15th)
- The fire occurred. (09:38 March 15th) TEPCO reported that the fire was extinguished spontaneously. (Around 11:00 March 15th)
- The fire occurred. (05:45 March 16th) TEPCO reported that no fire could be confirmed on the ground. (Around 06:15 March 16th)
- The Self-Defence Force started water spray over the Spent Fuel Pool. (09:43 March 20th)
- On-site survey for leading electric cable (From 11:00 till 16:00 March 20th)
- Water spray over the Spent Fuel Pool by Self-Defense Force was started. (From around 18:30 till 19:46 March 20th).
- Water spray over the Spent Fuel Pool by Self-Defence Force using 13 fire engines was started (From 06:37 till 08:41 March 21st).
- Works for laying electric cable to the Power Center was completed. (Around 15:00 March 21st)
- Power Center received electricity. (10:35 March 22nd)
- Seawater spray of around 150t using Concrete Pump Truck (50t/h) was carried out. (From 17:17 till 20:32 March 22nd)
- Seawater spray of around 130t using Concrete Pump Truck (50t/h) was carried out. (From 10:00 till 13:02 March 23rd)
- Seawater spray of around 150t using Concrete Pump Truck (50t/h) was carried out. (From 14:36 till 17:30 March 24th)
- Seawater spray of around 150t using Concrete Pump Truck (50t/h) was carried out. (From 19:05 till 22:07 March 25th)
- Seawater injection to the Spent Fuel Pool via the Spent Fuel Pool Cooling Line was carried out. (From 06:05 till 10:20 March 25th)
- Seawater spray of around 125t using Concrete Pump Truck (50t/h) was

- carried out. (From 16:55 till 19:25 March 27th)
- Lighting of Central Operation Room was recovered. (11:50 March 29th)
- Fresh water spray of around 140t using Concrete Pump Truck (50t/h) was carried out. (From 14:04 till 18:33 March 30th)
- Fresh water spray of around 180t using Concrete Pump Truck (50t/h) was carried out. (From 08:28 till 14:14 April 1st)
- Lighting in the turbine building was partially turned on. (April 2nd)
- From 2 April, the stagnant water in the Main Building of Radioactive Waste Treatment Facilities was being transferred to the turbine building of Unit 4. As the water level in the vertical portion of the trench for Unit 3 rose from 3 April, by way of precaution, the transfer was suspended notwithstanding that the path of the water was not clear. (09:22 April 4th)
- Fresh water spray of around 180t using Concrete Pump Truck (50t/h) was carried out. (From 17:14 till 22:16 April 3rd)
- Fresh water spray of around 20t using Concrete Pump Truck (50t/h) was carried out. (From 17:35 till 18:22 April 5th)
- Fresh water spray of around 38t using Concrete Pump Truck (50t/h) was carried out. (From 18:23 till 19:40 April 7th)
- Fresh water spray of around 90t using Concrete Pump Truck (50t/h) was carried out. (From 17:07 till 19:24 April 9th)
- The work for sampling water in the Spent Fuel Pool was carried out in order to grasp the conditions of the fuels that are kept in the pool. (From 12:00 till 13:04 April 12th)
- The occurrence of earthquake. (Around 17:16 April 11th)
- Fresh water spray of around 195t using Concrete Pump Truck (50t/h) was carried out. (From 0:30 till 6:57 April 13th)
- White smoke was not confirmed to generate. (As of 06:30 April 14th)

<Units 5 and 6>

- The first unit of Emergency Diesel Generator (D/G) (B) for Unit 6 is operating and supplying electricity. Water injection to RPV and the Spent Fuel Pool through the system of Make up Water Condensate (MUWC) is being carried out.
- The second unit of Emergency Diesel Generator (D/G) (A) for Unit 6 started up. (04:22 March 19th)

- The pumps for Residual Heat Removal (RHR) (C) for Unit 5 (05:00 March 19th) and RHR (B) for Unit 6 (22:14 March 19th) started up and recovered heat removal function. It cools Spent Fuel Pool with priority. (Power supply : Emergency Diesel Generator for Unit 6) (05:00 March 19th)
- Unit 5 under cold shut down (14:30 March 20th)
- Unit 6 under cold shut down (19:27 March 20th)
- Receiving electricity reached to the transformer of starter. (19:52 March 20th)
- Power supply to Unit 5 was switched from the Emergency Diesel Generator to external power supply. (11:36 March 21st)
- Power supply to Unit 6 was switched from the Emergency Diesel Generator to external power supply. (19:17 March 22nd)
- The temporary pump for RHR Seawater System (RHRS) of Unit 5 was automatically stopped when the power supply was switched from the temporary to the permanent. (17:24 March 23rd)
- Repair of the temporary pump for RHRS of Unit 5 was completed (16:14 March 24th) and cooling was started again. (16:35 March 24th)
- Power supply for the temporary pump for RHRS of Unit 6 was switched from the temporary to the permanent. (15:38 and 15:42 March 25th)
- The groundwater with low-level radioactivity in the Sub Drain Pit of Units 5 and 6 (Around 1,500t) was started to be discharged through the Water Discharge Canal to the sea. (21:00 April 4th)
- The groundwater with low-level radioactivity in the Sub Drain Pit of Units 5 and 6 (Around 1,500t) was discharged through the Water Discharge Canal to the sea. (Unit5 from 21:00 April 4th till 12:14 April 8th (Around 950t), Unit6 from 21:00 April 4th till 18:52 April 9th (Around 373t))
- The occurrence of earthquake. (Around 17:16 April 11th)

<Common Spent Fuel Pool>

- It was confirmed that the water level of Spent Fuel Pool was maintained almost full at after 06:00 March 18th.
- Water spray over the Common Spent Fuel Pool was started. (From 10:37 till 15:30 March 21st)
- The power was started to be supplied (15:37 March 24th) and cooling

was also started. (18:05 March 24th)

- As of 08:00 April 13th, water temperature of the pool was around 29°C.

<Other>

- As the result of nuclide analysis at around the Southern Water Discharge Canal, $7.4 \times 10^1 \text{Bq/cm}^3$ of ^{131}I (Iodine) (1,850.5 times higher than the concentration limit in water outside the Environmental Monitoring Area) was detected. (14:30 March 26th)

(As the result of measurement on 29 March, it was detected as 3,355.0 times higher than the limit in water (13:55 March 29th). On the other hand, as the result of the analysis at the northern side of the Water Discharge Canal of the NPS, $4.6 \times 10^1 \text{Bq/cm}^3$ of ^{131}I (Iodine) (1,262.5 times higher than the limit in water) was detected. (14:10 March 29th)

- The water was confirmed to be collected in the vertical parts of the trenches (an underground structure for laying pipes, shaped like a tunnel) outside of the turbine building of Units 1 to 3. The dose rates on the water surface were 0.4 mSv/h of the Unit 1's trench and 1,000 mSv/h of the Unit 2's trench. The rate of the Unit 3's trench could not measure because of the rubble. (Around 15:30 March 27th) The collected water in the vertical part of the trench outside of the turbine building of Unit 1 was transferred to the storage tank in the Main Building of Radioactive Waste Treatment Facilities by the temporary pump. Thereafter the water level from the top of the vertical part went down from approximately -0.14m to approximately -1.14m. (From 09:20 till 11:25 March 31st)
- In the samples of soil collected on 21 and 22 March on the site (at 5 points) of Fukushima Dai-ichi NPS, ^{238}Pu (Plutonium), ^{239}Pu (Plutonium) and ^{240}Pu (Plutonium) were detected (23:45 March 28th announced by TEPCO). The concentration of the detected plutonium was at the equivalent level of the fallout (radioactive fallout) that was observed in Japan concerning the past atmospheric nuclear testing, i.e. at the equivalent level of the normal condition of environment, and was not at the level of having harmful influence on human body.
- When removing the flange of pipes of Residual Heat Removal Seawater System outside the building of Unit 3, three subcontractor's employees were wetted by the water remaining in the pipe. However, as the result

- of wiping the water off, no radioactive materials were attached to their bodies. (12:03 March 29th)
- On March 28th, the stagnant water was confirmed in the Main Building of Radioactive Waste Treatment Facilities. As the result of analysis of radioactivity, the total amount of the radioactivity 1.2×10^1 Bq/cm³ in the controlled area and that of 2.2×10^1 Bq/cm³ in the non-controlled area were detected in March 29th.
 - As the result of nuclide analysis at around the Southern Water Discharge Canal, 1.8×10^2 Bq/cm³ of ¹³¹I (Iodine) (4,385.0 times higher than the concentration limit in water outside the Environmental Monitoring Area) was detected (13:55 March 30th).
 - The barge (the first ship) of the US armed forces carrying fresh water for cooling reactors, etc. landed in the exclusive port of the power station, being towed by the ships of Maritime Self-Defense Force. (15:42 March 31st) The transfer of fresh water from the barge (the first ship) to the Filtrate Tank was started. (15:58 April 1st) Thereafter it was suspended due to the malfunction of the hose (16:25 April 1st), but was resumed on April 2nd. (From 10:20 till 16:40 April 2nd)
 - The permanent monitoring posts (No.1 to 8) installed near the Site Boundary were recovered. (March 31st) They are measuring once a day.
 - The test implementation of spraying anti-scattering agent to prevent the spread of radioactive materials on the ground surface was carried out in the area of about 500 m² on the mountain-side of the Common Pool. (From 15:00 till 16:05 April 1st)
 - The barge (the second ship) of the US armed forces carrying fresh water for cooling reactors, etc. landed in the exclusive port of the power station, being towed by the ships of Maritime Self-Defense Force. (9:10 April 2nd)
 - The freshwater was transferred from the barge (the second ship) of the US armed force to the barge (the first ship). (From 09:52 till 11:15 April 3rd)
 - The stagnant water with low-level radioactivity in the Main Building of Radioactive Waste Treatment Facilities was started to be discharged from the southern side of the Water Discharge Canal to the sea, using the first pump. (19:03 April 4th) Further, the discharge using 10 pumps in total was carried out (19:07 April 4th) and stopped discharging to the

sea using submersible pumps at 17:40 April 10th. Confirmation of the remaining water is being carried out. (Total amount of discharged water is around 9,070t.)

- In the samples of soil (7 samples in total) collected on 25 March (at 4 points) and 28 March (at 3 points) on the site of Fukushima Dai-ichi NPS, ^{238}Pu (Plutonium), ^{239}Pu (Plutonium) and ^{240}Pu (Plutonium) were detected (18:30 April 6th announced by TEPCO). The concentration of the detected plutonium was, in the same as the last one (Announced on 28 March), at the equivalent level of the fallout (radioactive fallout) that was observed in Japan concerning the past atmospheric nuclear testing, i.e. at the equivalent level of the normal condition of environment, and was not at the level of having harmful influence on human body.
- In order to prevent the outflow of the contaminated water from the exclusive port, the work for stopping water by means of large-sized sandbags was implemented around the seawall on the south side of the NPS. (From 15:00 till 16:30 April 5th)
- The test implementation of spraying anti-scattering agent to prevent the spread of radioactive materials on the ground surface was carried out in the area of about 600 m² on the mountain-side of the Common Pool. (From 13:00 till 16:30 April 5th, From 12:30 till 14:30 April 6th)
- The stagnant water with low-level radioactivity in the Building of Miscellaneous Solid Waste Volume Reduction Processing was discharged from the southern side of the Water Discharge Canal to the sea using 5 pumps. (From 17:20 April 6th till 18:20 April 7th)
- In order to prepare to transfer the stagnant water in the turbine buildings to the Radioactive Waste Treatment Facilities, drilling the outer walls of the turbine buildings of Units 2 to 4 was carried out. (April 7th)
- The test implementation of spraying anti-scattering agent to prevent the spread of radioactive materials on the ground surface was carried out in the area of about 680 m² on the mountain-side of the Common Pool. (From 11:00 till 14:00 April 8th)
- The pumping out of the water in the Radioactive Waste Treatment Facilities, which was suspended by the earthquake off the coast of Miyagi Prefecture occurred at 11:32 April 7th, was resumed. (14:30 April 8th)
- The test implementation of spraying antiscattering agent to prevent the spread of radioactive materials on the ground surface was carried out in

- the area of about 550 m² on the mountain-side of the Common Pool. (From 13:00 till 14:00 April 10th)
- Removal of the rubble using remote-control heavy machineries was carried out. (April 10th)
 - Videotaping using a wireless helicopter was carried out in order to grasp the situations of reactor buildings for Units 1 to 4. (From 15:59 till 16:28 April 10th)
 - The silt fences to prevent the spread of the contaminated water were completed to be doubly installed at the appropriate part of the seawall on the south side of the NPS.
 - The test implementation of spraying anti-scattering agent to prevent the spread of radioactive materials on the ground surface was carried out in the area of about 1,200 m² on the mountain-side of the Common Pool. (From 12:00 till 13:00 April 11th)
 - It was confirmed that a fire occurred at the Building for Water Discharge Canal Sampling for Units 1 to 4. (Around 6:38 April 12th) It was confirmed that there were no fire and smoke as a result of the initial activity of fire fighting. (Just before 07:00 on the same day) The fire was then confirmed to be completely under control. (09:12 on the same day)
 - The test implementation of spraying anti-scattering agent to prevent the spread of radioactive materials on the ground surface was carried out, in the area of about 700 m² on the mountain-side of the Common Pool. (April 12th)
 - On the ocean-side of the Inlet Bar Screen of Unit 2, the temporary board to stop water (one of the 7 steel plates) was installed. (From 12:00 till 13:00 April 12th)
 - On the ocean-side of the Inlet Bar Screen of Unit 2, the temporary boards to stop water (2 of the 7 steel plates) was installed. (From around 8:30 till around 10:00 April 13th)
 - The silt fence to prevent the spread of the contaminated water was completed to be installed in front of the Screen of Units 3 and 4. (13:50 April 13th)
 - The test implementation of spraying antiscattering agent to prevent the spread of radioactive materials on the ground surface was carried out, in the area of about 400 m² on the mountain-side of the Common Pool. (From 11:00 till 11:30 April 13th)

- Removal of rubble (Amounts equivalent to 6 containers) using remote-control heavy machineries was carried out. (From 11:00 till 16:10 April 13th)
- The silt fences to prevent the spread of the contaminated water were installed at the Curtain Wall and in front of the Screen of Units 1 and 2. (12:20 April 14th)
- Videotaping using a wireless helicopter was carried out in order to grasp the situations of reactor buildings for Units 3 and 4. (From 10:17 till 12:25 April 14th)

● Fukushima Dai-ni NPS (TEPCO)

(Naraha Town / Tomioka Town, Futaba County, Fukushima Prefecture.)

(1) The state of operation

- Unit1 (1,100MWe): automatic shutdown, cold shut down at 17:00, March 14th
- Unit2 (1,100MWe): automatic shutdown, cold shut down at 18:00, March 14th
- Unit3 (1,100MWe): automatic shutdown, cold shut down at 12:15, March 12th
- Unit4 (1,100MWe): automatic shutdown, cold shut down at 07:15, March 15th

(2) Major plant parameters (As of 12:00 April 14th)

	Unit	Unit 1	Unit 2	Unit 3	Unit 4
Reactor Pressure*1	MPa	0.15	0.14	0.10	0.17
Reactor water temperature	℃	25.2	24.8	32.9	29.1
Reactor water level*2	mm	9,296	10,346	7,795	8,785
Suppression pool water temperature	℃	24	24	26	30
Suppression pool pressure	kPa (abs)	104	105	111	109
Remarks		cold shutdown	cold shutdown	cold shutdown	cold shutdown

*1: Converted from reading value to absolute pressure

*2: Distance from the top of fuel

(3) Situation of Each Unit

<Unit 1>

- Around 17:56 March 30th, smoke was rising from the power distribution panel on the first floor of the turbine building of Unit 1. However, when the power supply was turned off, the smoke stopped to generate. It was judged by the fire station at 19:15 that this event was caused by the malfunction of the power distribution panel and was not a fire.
- The Residual Heat Removal System (B) to cool the reactor of Unit 1 became to be able to receive power from the emergency power supply as well as the external power supply. This resulted in securing the backup power supplies (emergency power supplies) of Residual Heat Removal System (B) for all Units. (14:30 March 30th)

(4) Report concerning other incidents

- TEPCO reported to NISA the event in accordance with the Article 10 of the Act on Special Measures Concerning Nuclear Emergency Preparedness regarding Unit 1. (18:08 March 11th)
- TEPCO reported to NISA the events in accordance with the Article 10 regarding Units 1, 2 and 4. (18:33 March 11th)
- TEPCO reported to NISA the event (Loss of pressure suppression functions) falling under the Article 15 of the Act on Special Measures Concerning Nuclear Emergency Preparedness regarding Unit 1. (5:22 March 12th)
- TEPCO reported to NISA the event (Loss of pressure suppression functions) falling under the Article 15 of the Act on Special Measures Concerning Nuclear Emergency Preparedness regarding Unit 2. (5:32 March 12th)
- TEPCO reported to NISA the event (Loss of pressure suppression function) falling under the Article 15 of the Act on Special Measures Concerning Nuclear Emergency Preparedness regarding Unit 4 of Fukushima Dai-ni NPS. (6:07 March 12th)

● Onagawa NPS (Tohoku Electric Power Co. Inc.)

(Onagawa Town, Oga County and Ishinomaki City, Miyagi Prefecture)

(1) The state of operation

Unit 1 (524MWe): automatic shutdown, cold shut down at 0:58, March

12th
Unit 2 (825MWe): automatic shutdown, cold shut down at earthquake
Unit 3 (825MWe): automatic shutdown, cold shut down at 1:17, March
12th

(2) Readings of monitoring post, etc.

MP2 (Monitoring at the Northern End of Site Boundary)

Approx. 0.32 μ SV/h (16:00 April 13th) (Approx. 0.33 μ SV/h (16:00 April
12th))

(3) Report concerning other incidents

- Fire Smoke on the first basement of the Turbine Building was confirmed to be extinguished. (22:55 on March 11th)
- Tohoku Electric Power Co. reported to NISA in accordance with the Article 10 of the Act on Special Measures Concerning Nuclear Emergency Preparedness. (13:09 March 13th)

2. Action taken by NISA

(March 11th)

- 14:46 Set up of the NISA Emergency Preparedness Headquarters (Tokyo) immediately after the earthquake
- 15:42 TEPCO reported to NISA in accordance with the Article 10 of the Act on Special Measures Concerning Nuclear Emergency Preparedness regarding Fukushima Dai-ichi NPS.
- 16:36 TEPCO recognized the event (Inability of water injection of the Emergency Core Cooling System) in accordance with the Article 15 of the Act on Special Measures Concerning Nuclear Emergency Preparedness regarding Units 1 and 2 of Fukushima Dai-ichi NPS. (Reported to NISA at 16:45)
- 18:08 Regarding Unit 1 of Fukushima Dai-ni NPS, TEPCO reported to NISA in accordance with the Article 10 of the Act on Special Measures Concerning Nuclear Emergency Preparedness.
- 18:33 Regarding Units 1, 2 and 4 of Fukushima Dai-ni NPS, TEPCO reported to NISA in accordance with the Article 10 of Act on Special Measures Concerning Nuclear Emergency Preparedness.
- 19:03 The Government declared the state of nuclear emergency.

(Establishment of the Government Nuclear Emergency Response Headquarters and the Local Nuclear Emergency Response Headquarters)

- 20:50 Fukushima Prefecture's Emergency Response Headquarters issued a direction for the residents within 2 km radius from Unit 1 of Fukushima Dai-ichi NPS to evacuate. (The population of this area is 1,864.)
- 21:23 Directives from the Prime Minister to the Governor of Fukushima Prefecture, the Mayor of Okuma Town and the Mayor of Futaba Town were issued regarding the event occurred at Fukushima Dai-ichi NPS, TEPCO, in accordance with the Paragraph 3, the Article 15 of the Act on Special Measures Concerning Nuclear Emergency Preparedness as follows:
- Direction for the residents within 3km radius from Unit 1 of Fukushima Dai-ichi NPS to evacuate
 - Direction for the residents within 10km radius from Unit 1 of Fukushima Dai-ichi NPS to stay in-house
- 24:00 Vice Minister of Economy, Trade and Industry, Ikeda arrived at the Local Nuclear Emergency Response Headquarters

(March 12th)

- 0:49 Regarding Units 1 TEPCO Fukushima Dai-ichi NPS, TEPCO recognized the event (Unusual rise of the pressure in PCV) in accordance with the Article 15 of the Act on Special Measures Concerning Nuclear Emergency Preparedness. (Reported to NISA at 01:20)
- 05:22 Regarding Unit 1 of Fukushima Dai-ichi NPS, TEPCO recognized the event (Loss of pressure suppression function) to fall under the Article 15 of the Act on Special Measures Concerning Nuclear Emergency Preparedness. (Reported to NISA at 06:27)
- 05:32 Regarding Unit 2 of Fukushima Dai-ichi NPS, TEPCO recognized the event (Loss of pressure suppression function) to fall under the Article 15 of the Act on Special Measures Concerning Nuclear Emergency Preparedness.
- 05:44 Residents within 10km radius from Unit 1 of Fukushima Dai-ichi NPS shall evacuate by the Prime Minister Directive.

- 06:07 Regarding of Unit 4 of Fukushima Dai-ni NPS, TEPCO recognized the event (Loss of pressure suppression function) to fall under the Article 15 of the Act on Special Measures Concerning Nuclear Emergency Preparedness.
- 06:50 In accordance with the Paragraph 3, the Article 64 of the Nuclear Regulation Act, the order was issued to control the internal pressure of PCV of Units 1 and 2 of Fukushima Dai-ichi NPS.
- 07:45 Directives from the Prime Minister to the Governor of Fukushima Prefecture, the Mayors of Hirono Town, Naraha Town , Tomioka Town and Okuma Town were issued regarding the event occurred at Fukushima Dai-ni NPS, TEPCO, pursuant to the Paragraph 3, the Article 15 of the Act on Special Measures Concerning Nuclear Emergency Preparedness as follows:
- Direction for the residents within 3km radius from Fukushima Dai-ni NPS to evacuate
 - Direction for the residents within 10km radius from Fukushima Dai-ni NPS to stay in-house
- 17:00 TEPCO reported to NISA the event (Unusual increase of radiation dose at the site boundary) falling under the Article 15 of the Act on Special Measures Concerning Nuclear Emergency Preparedness regarding Fukushima Dai-ichi NPS.
- 17:39 The Prime Minister directed evacuation of the residents within the 10 km radius from Fukushima Dai-ni NPS.
- 18:25 The Prime Minister directed evacuation of the residents within the 20km radius from Fukushima Dai-ichi NPS.
- 19:55 Directives from the Prime Minister was issued regarding seawater injection to Unit 1 of Fukushima Dai-ichi NPS.
- 20:05 Considering the Directives from the Prime Minister and pursuant to the Paragraph 3, the Article 64 of the Nuclear Regulation Act, the order was issued to inject seawater to Unit 1 of Fukushima Dai-ichi NPS and so on.
- 20:20 At Unit 1 of Fukushima Dai-ichi NPS, seawater injection was started.

(March 13th)

- 05:38 TEPCO reported to NISA the event (Total loss of coolant injection function) falling under the Article 15 of the Act on Special Measures

Concerning Nuclear Emergency Preparedness regarding Unit 3 of Fukushima Dai-ichi NPS. Recovering efforts by TEPCO of the power source and coolant injection function and the work on venting were under way.

- 09:01 TEPCO reported to NISA the event (Unusual increase of radiation dose at the site boundary) falling under the Article 15 of the Act on Special Measures Concerning Nuclear Emergency Preparedness regarding Fukushima Dai-ichi NPS.
- 09:08 Pressure suppression and fresh water injection was started for Unit 3 of Fukushima Dai-ichi NPS.
- 09:20 The Pressure Vent Valve of Unit 3 of Fukushima Dai-ichi NPS was opened.
- 09:30 Directive was issued for the Governor of Fukushima Prefecture, the Mayors of Okuma Town, Futaba Town, Tomioka Town and Namie Town in accordance with the Act on Special Measures Concerning Nuclear Emergency Preparedness on the contents of radioactivity decontamination screening.
- 13:09 Tohoku Electric Power Co. reported to NISA that Onagawa NPS reached a situation specified in the Article 10 of the Act on Special Measures Concerning Nuclear Emergency Preparedness.
- 13:12 Fresh water injection was switched to seawater injection for Unit 3 of Fukushima Dai-ichi NPS.
- 14:36 TEPCO reported to NISA the event (Unusual increase of radiation dose at the site boundary) falling under the Article 15 of the Act on Special Measures Concerning Nuclear Emergency Preparedness regarding Fukushima Dai-ichi NPS.

(March 14th)

- 01:10 Seawater injection for Units 1 and 3 of Fukushima Dai-ichi NPS were temporarily interrupted due to the lack of seawater in pit.
- 03:20 Seawater injection for Unit 3 of Fukushima Dai-ichi NPS was resumed.
- 04:40 TEPCO reported to NISA the event (Unusual increase of radiation dose at the site boundary) falling under the Article 15 of the Act on Special Measures Concerning Nuclear Emergency Preparedness regarding Fukushima Dai-ichi NPS.

- 05:38 TEPCO reported to NISA the event (Unusual increase of radiation dose at the site boundary) falling under the Article 15 of the Act on Special Measures Concerning Nuclear Emergency Preparedness regarding Fukushima Dai-ichi NPS.
- 07:52 TEPCO reported to NISA the event (Unusual rise of the pressure in PCV) falling under the Article 15 of the Act on Special Measures Concerning Nuclear Emergency Preparedness regarding Unit 3 of Fukushima Dai-ichi NPS.
- 13:25 Regarding Unit 2 of Fukushima Dai-ichi NPS, TEPCO recognised the event (Loss of reactor cooling function) to fall under the Article 15 of the Act on Special Measures Concerning Nuclear Emergency Preparedness.
- 22:13 TEPCO reported to NISA in accordance with the Article 10 of the Act on Special Measures Concerning Nuclear Emergency Preparedness regarding Fukushima Dai-ichi NPS.
- 22:35 TEPCO reported to NISA the event (Unusual increase of radiation dose at the site boundary) falling under the Article 15 of the Act on Special Measures Concerning Nuclear Emergency Preparedness regarding Fukushima Dai-ichi NPS.

(March 15th)

- 00:00: The acceptance of experts from International Atomic Energy Agency (IAEA) was decided. NISA agreed to accept the offer of dispatching of the expert on NPS damage from IAEA considering the intention by Mr. Amano, Director General of IAEA. Therefore, the schedule of expert acceptance will be planned from now on according to the situation.
- 00:00: NISA also decided the acceptance of experts dispatched from U.S. Nuclear Regulatory Commission (NRC).
- 07:21 TEPCO reported to NISA the event (Unusual increase of radiation dose at the site boundary) falling under the Article 15 of the Act on Special Measures Concerning Nuclear Emergency Preparedness regarding Fukushima Dai-ichi NPS.
- 07:24 Incorporated Administration Agency, Japan Atomic Energy Agency (JAEA) reported to NISA in accordance with the Article 10 of the Act on Special Measures Concerning Nuclear Emergency Preparedness

- regarding Nuclear Fuel Cycle Engineering Laboratories, Tokai Research and Development Centre.
- 07:44 JAEA reported to NISA in accordance with the Article 10 of the Act on Special Measures Concerning Nuclear Emergency Preparedness regarding Nuclear Science Research Institute.
- 08:54 TEPCO reported to NISA the event (Unusual increase of radiation dose at the site boundary) falling under the Article 15 of the Act on Special Measures Concerning Nuclear Emergency Preparedness regarding Fukushima Dai-ichi NPS.
- 10:30 According to the Nuclear Regulation Act, the Minister of Economy, Trade and Industry issued the directions as follows.
- For Unit 4: To extinguish fire and to prevent the occurrence of re-criticality
- For Unit 2: To inject water to reactor vessel promptly and to vent Drywell.
- 10:59 Considering the possibility of lingering situation, it was decided that the function of the Local Nuclear Emergency Response Headquarters was moved to the Fukushima Prefectural Office.
- 11:00 The Prime Minister directed the in-house stay area.
- In-house stay was additionally directed to the residents in the area from 20 km to 30 km radius from Fukushima Dai-ichi NPS considering in-reactor situation.
- 16:30 TEPCO reported to NISA the event (Unusual increase of radiation dose at the site boundary) falling under the Article 15 of the Act on Special Measures Concerning Nuclear Emergency Preparedness regarding Fukushima Dai-ichi NPS.
- 22:00 According to the Nuclear Regulation Act, the Minister of Economy, Trade and Industry issued the following direction.
- For Unit 4: To implement the water injection to the Spent Fuel Pool.
- 23:46 TEPCO reported to NISA the event (Unusual increase of radiation dose at the site boundary) falling under the Article 15 of the Act on Special Measures Concerning Nuclear Emergency Preparedness regarding Fukushima Dai-ichi NPS.

(March 18th)

13:00 Ministry of Education, Culture, Sports, Science and Technology

decided to reinforce the nation-wide monitoring survey in the emergency of Fukushima Dai-ichi and Dai-ni NPS.

15:55 TEPCO reported to NISA on the accidents and failure at Units 1, 2, 3 and 4 of Fukushima Dai-ichi NPS (Leakage of the radioactive materials inside of the reactor buildings to non-controlled area of radiation) pursuant to the Article 62-3 of the Nuclear Regulation Act.

16:48 Japan Atomic Power Co. reported to NISA accidents and failures in Tokai NPS (Failure of the seawater pump motor of the Emergency Diesel Generator 2C) pursuant to the Article 62-3 of the Nuclear Regulation Act.

(March 19th)

07:44 The second unit of Emergency Diesel Generator (A) for Unit 6 started up.

TEPCO reported to NISA that the pump for RHR (C) for Unit 5 started up and started to cooling Spent Fuel Storage Pool. (Power supply: Emergency Diesel Generator for Unit 6)

08:58 TEPCO reported to NISA the event (Unusual increase of radiation dose at the site boundary) falling under the Article 15 of the Act on Special Measures Concerning Nuclear Emergency Preparedness regarding Fukushima Dai-ichi NPS.

(March 20th)

23:30 Directive from Local Nuclear Emergency Response Headquarters to the Prefectural Governor and the heads of cities, towns and villages (Tomioka Town, Hutaba Town, Okuma Town, Namie Town, Kawauchi Village, Naraha Town, Minamisoma City, Tamura City, Kazurao Village, Hirono Town, Iwaki City and Iidate Village) was issued regarding the change of the reference value for the screening level for decontamination of radioactivity.

(March 21st)

07:45 Directive titled as “Administration of the stable Iodine” was issued from Local Nuclear Emergency Response Headquarters to the Prefectural Governor and the heads of cities, towns and villages (Tomioka Town, Hutaba Town, Okuma Town, Namie Town, Kawauchi

Village, Naraha Town, Minamisouma City, Tamura City, Kazurao Village, Hirono Town, Iwaki City and Iidate Village), which directs the above-mentioned governor and the heads to administer stable Iodine under the direction of the headquarters and in the presence of medical experts, and not to administer it on personal judgements.

16:45 Directive titled as “Ventilation for using heating equipments within the in-house evacuation zone” was issued from the Director-General of Local Nuclear Emergency Response Headquarters to the Prefectural Governor and the heads of cities, towns and villages (Tomioka Town, Hutaba Town, Okuma Town, Namie Town, Kawauchi Village, Naraha Town, Minamisouma City, Tamura City, Kazurao Village, Hirono Town, Iwaki City and Iidate Village), which directs the above-mentioned governor and heads to publicly announce the guidance to the residents within the in-house evacuation zone, concerning the indoor use of heating equipments that require ventilation, in order to avoid poisoning from carbon monoxide and to reduce exposure.

17:50 Directive from the Director-general of the Government Nuclear Emergency Response Headquarters to the Prefectural Governors of Fukushima, Ibaraki, Tochigi and Gunma was issued, which direct the above-mentioned governors to issue a request to relevant businesses and people to suspend shipment of spinach, *Kakina* (a green vegetable) and raw milk for the time being.

(March 22nd)

16:00 NISA received the response (Advice) from Nuclear Safety Commission Emergency Technical Advisory Body to the request for advice made by NISA, regarding the report from TEPCO titled as “The Results of Analysis of Seawater” dated March 22nd.

(March 25th)

NISA directed orally to the TEPCO regarding the exposure of workers at the turbine building of Unit 3 of Fukushima Dai-ichi Nuclear Power Station occurred on March 24th, to review immediately and to improve its radiation control measures from the viewpoint of preventing a recurrence.

(March 28th)

Regarding the mistake in the evaluation of the concentration measurement in the stagnant water on the basement floor of the turbine building of Unit 2 of Fukushima Dai-ichi NPS announced by TEPCO on 27 March, NISA directed TEPCO orally to prevent the recurrence of such a mistake.

13:50 Receiving the suggestion by the special meeting of Nuclear Safety Commission (NSC) (Stagnant water on the underground floor of the turbine building at Fukushima Dai-ichi Plant Unit 2), NISA directed TEPCO orally to add the sea water monitoring points and carry out the groundwater monitoring.

Regarding the delay in the reporting of the water confirmed outside of the turbine buildings, NISA directed TEPCO to accomplish the communication in the company on significant information in a timely manner and to report it in a timely and appropriate manner.

(March 29th)

11:16 The report was received, regarding the accident and trouble etc. in Onagawa NPS of Tohoku Electric Power Co. Inc. (the trouble of pump of component cooling water system etc. in Unit 2 and the fall of heavy oil tank for auxiliary boiler of Unit 1 by tsunami), pursuant to the Article 62-3 of the Nuclear Regulation Act and the Article 3 of the Ministerial Ordinance for the Reports related to Electricity.

In order to strengthen the system to assist the nuclear accident sufferers, the "Team to Assist the Lives of the Nuclear Accident Sufferers" headed by the Minister of Economy, Trade and Industry was established and the visits, etc. by the team to relevant cities, towns and villages were carried out.

The Local Nuclear Emergency Response Headquarters issued the News Letter No.1 for the residents within the area from 20 km to 30 km radius.

(March 30th)

Directions as to the implementation of the emergency safety measures for the other power stations considering the accident of Fukushima Dai-ichi and Dai-ni NPSs in 2011 was issued and handed

to each electric power company and the relevant organization.

(March 31st)

Regarding the break-in of the propaganda vehicle to Fukushima Dai-ni NPS on 31 March, NISA directed TEPCO orally to take the carefully thought-out measures regarding physical protection, etc.

NISA alerted TEPCO to taking the carefully thought-out measures regarding radiation control for workers.

The Local Nuclear Emergency Response Headquarters issued the News Letter No.2 for the residents within the area from 20 km to 30 km radius.

(April 1st)

NISA strictly alerted TEPCO to taking appropriate measures concerning the following three matters regarding the mistake in the result of nuclide analysis.

- Regarding the past evaluation results on nuclide analysis, all the nuclides erroneously evaluated should be identified and the re-evaluation on them should be promptly carried out.
- The causes for the erroneous evaluation should be investigated and the thorough measures for preventing the recurrence should be taken.
- Immediate notification should be done in the stage when any erroneous evaluation results, etc. are identified.

(April 2nd)

Regarding the outflow of the liquid including radioactive materials from the area around the Intake Channel of Unit 2 of Fukushima Dai-ichi NPS, NISA directed TEPCO orally to carry out nuclide analysis of the liquid sampled, to confirm whether there are other outflows from the same parts of the facilities as the one, from which the outflow was confirmed around the Unit 2, and to strengthen monitoring through sampling water at more points around the facilities concerned.

(April 4th)

On the imperative execution of the discharge to the sea as an emergency measure, NISA requested the technical advice of NSC and directed TEPCO to survey and confirm the impact of the spread of radioactive materials caused by the discharge, by ensuring continuity of the sea monitoring currently underway and enhancing it (Increase of the frequency of measuring as well as the number of monitoring points), disclose required information, as well as to enhance the strategy to minimize the discharge amount.

(April 5th)

Directions as to the implementation of advance notification and contact to the local governments with regard to taking measures related to discharge of radioactive materials from Fukushima Dai-ichi NPS, which have a possible impact on the environment, was issued.

(April 6th)

On the implementation of the nitrogen injection to PCV of Unit 1, NISA directed TEPCO on the following three points. (12:40 April 6th)

- ① Properly control the plant parameters, and take measures appropriately to ensure safety in response to changes in the parameters.
- ② Establish and implement an organizational structure and so on that will ensure the safety of the workers who will engage in the operation.
- ③ As the possibility of leakage of the air in PCV to the outside due to the nitrogen injection cannot be ruled out, through the judicious and further enhanced monitoring, TEPCO shall survey and confirm the impact of the release and spreading of radioactive materials due to the nitrogen injection, and strive to disclose information.

(April 7th)

The Local Nuclear Emergency Response Headquarters issued the News Letter No.3 for the residents within the area from 20km to 30km radius. (April 7th)

(April 9th)

Due to the earthquake off the coast of Miyagi Prefecture occurred around 23:32 April 7th, all the Emergency Diesel Generators for Unit 1 of the Higashidori NPS of Tohoku Electric Power Co., Inc. were not workable. Considering this event, NISA issued the letters of direction titled "Regarding the Treatment of Emergency Power Generating Facilities in Terms of Safety Regulations (Directions)" to each Electricity Utility and other organizations concerned.

In accordance with the Paragraph 1, the Article 67 of the Nuclear Regulation Act, NISA issued the direction regarding collection of report that should include the evaluation of necessity and safety, and the policy of ensuring the permanent storage and treatment facilities for the waste water and so on, concerning the transfer of the stagnant water with high-level radioactivity in Fukushima Dai-ichi NPS to the Radioactive Waste Treatment Facilities.

(April 10th)

In accordance with Article 67, paragraph 1 of the Nuclear Regulation Act, NISA issued the direction regarding collection of report that should include the necessity, the evaluation of safety and the policy of ensuring the permanent storage and treatment facilities for the waste water and so on, concerning the transfer of the stagnant water with high-level radioactivity in Fukushima Dai-ichi NPS to the Radioactive Waste Treatment Facilities.

(April 13th)

- In accordance with paragraph 1, Article 67 of the Nuclear Regulation Act, NISA directed TEPCO to report the result of implementation on seismic safety evaluation as well as the result of consideration on the measurement of effective seismic reinforcement work, etc., regarding the buildings of Fukushima Dai-ichi NPS.

- NISA directed TEPCO to implement detailed analysis and consideration regarding the tsunami caused by the 2011 Tohoku District - off the Pacific Ocean Earthquake.

- NISA directed Tohoku Electric Power Co. Inc. to report the analysis of seismic data observed when the 2011 Earthquake off the Coast of Miyagi Prefecture occurred around 23:32 on 7 April and the assessment on seismic impact on the facilities that are important from

the seismic safety viewpoints.

< Possibility on radiation exposure (As of 15:30 April 14th) >

1. Exposure of residents

- (1) Including the about 60 evacuees from Futaba Public Welfare Hospital to Nihonmatsu City Fukushima Gender Equality Centre, as the result of measurement of 133 persons at the Centre, 23 persons counted more than 13,000 cpm were decontaminated.
- (2) The 35 residents transferred from Futaba Public Welfare Hospital to Kawamata Town Saiseikai Kawamata Hospital by private bus arranged by Fukushima Prefecture were judged to be not contaminated by the Prefectural Response Centre.

(3) As for the about 100 residents in Futaba Town evacuated by bus, the results of measurement for 9 of the 100 residents were as follows. The evacuees, moving outside the Prefecture (Miyagi Prefecture), were divided into two groups, which joined later to Nihonmatsu City Fukushima Gender Equality Centre.No. of Counts	No. of Persons
18,000 cpm	1
30,000-36,000 cpm	1
40,000 cpm	1
little less than 40,000 cpm*	1
very small counts	5

*(These results were measured without shoes, though the first measurement exceeded 100,000 cpm.)

- (4) The screening was started at the Off site Centre in Okuma Town from

March 12th to 15th. 162 people received examination until now. At the beginning, the reference value was set at 6,000 cpm. 110 people were at the level below 6,000 cpm and 41 people were at the level of 6,000 cpm or more. When the reference value was increased to 13,000 cpm afterward, 8 people were at the level below 13,000 cpm and 3 people are at the level of 13,000 cpm or more.

The 5 out of 162 people examined were transported to hospital after being decontaminated.

- (5) The Fukushima Prefecture carried out the evacuation of patients and personnel of the hospitals located within 10km area. The screening of all the members showed that 3 persons have the high counting rate. These members were transported to the secondary medical institute of exposure. As a result of the screening on 60 fire fighting personnel involved in the transportation activities, the radioactivity higher than twice of the back ground was detected on 3 members. Therefore, all the 60 members were decontaminated.
- (6) Fukushima Prefecture has started the screening from 13 March. It is carried out at the evacuation sites and the 11 places (set up permanently) such as health offices. Up until April 12th, the screening was done to 147,222 people. Among them, 102 people were above the 100,000 cpm, but when measured these people again without clothes, etc., the counts decreased to 100,000 cpm and below, and there was no case which affects health.

2. Exposure of workers

As for the workers conducting operations in Fukushima Dai-ichi NPS, the total number of people who were at the level of exposure more than 100 mSv becomes 28.

For two out of the three workers who were confirmed to be at the level of exposure more than 170 mSv on March 24, the attachment of radioactive material on the skin of both legs was confirmed. As the two workers were judged to have a possibility of beta ray burn, they were transferred to the Fukushima Medical University Hospital, and after that, on March 25th, all of the three workers arrived at the National Institute

of Radiological Sciences in the Chiba Prefecture. As the result of examination, the level of exposure of their legs was estimated to be from 2 to 3 Sv. The level of exposure of both legs and internal did not require medical treatment, but they decided to monitor the progress of all three workers in the hospital. All the three workers have been discharged from the hospital around the noon on 28 March. The three workers had the second medical examination at the National Institute of Radiological Sciences on 11 April, as a result, there was no problem regarding the condition of their health. The two workers who had been partially exposed to radiation on their skin of both legs were judged that any conditions of burn or red spots were not found on their skin.

At around 11:35 April 1st, a worker fell into the sea when he went on board the barge of the US Armed forces in order to adjust the hose. He was rescued immediately by other workers around without any injury and external contamination. In order to make double sure, the measurement by a whole-body counter was implemented. As a result, it was evaluated that there was no internal radionuclide contaminant on April 12th.

3. Others

- (1) 4 members of Self-Defence Force who worked in Fukushima Dai-ichi NPS were injured by explosion. One member was transferred to National Institute of Radiological Sciences. After the examination, judged that there were wounds but no risk for health from the exposure, the one was released from the hospital on March 17th. No other exposure of the Self-Defence Force member was confirmed at the Ministry of Defence.
- (2) As for policeman, the decontaminations of two policemen were confirmed by the National Police Agency. Nothing unusual was reported.
- (3) On March 24th, examinations of thyroid gland for 66 children aged from 1 to 15 years old were carried out at the Kawamata Town public health Center. The result was at not at the level of having harmful influence.
- (4) From March 26th to 27th, examinations of thyroid gland for 137 children aged from 0 to 15 years old were carried out at the Iwaki City Public Health Center. The result was not at the level of having harmful influence.
- (5) From March 28th to 30th, examinations of thyroid gland for 946 children aged from 0 to 15 years old were carried out at the Kawamata Town

Community Center and the Iidate Village Office. The result was not at the level of having harmful influence.

<Directive of screening levels for decontamination of radioactivity>

- (1) On March 20th, the Local Nuclear Emergency Response Headquarters issued the directive to change the reference value for the screening level for decontamination of radioactivity as the following to the Prefectural Governor and the heads of cities, towns and villages (Tomioka Town, Hutaba Town, Okuma Town, Namie Town, Kawauchi Village, Naraha Town, Minamisouma City, Tamura City, Kazurao Village, Hirono Town, Iwaki City and Iidate Village).

Old: 40 Bq/cm² measured by a gamma-ray survey meter or 6,000 cpm

New: 1 μ Sv/hour (dose rate at 10cm distance) or 100,000cpm equivalent

<Directives of administrating stable Iodine during evacuation>

- (1) On March 16th, the Local Nuclear Emergency Response Headquarters issued “Directive to administer the stable Iodine during evacuation from the evacuation area (20 km radius)” to the Prefectural Governor and the heads of cities, towns and villages (Tomioka Town, Hutaba Town, Okuma Town, Namie Town, Kawauchi Village, Naraha Town, Minamisouma City, Tamura City, Kazurao Village, Hirono Town, Iwaki City and Iidate Village).
- (2) On March 21st, the Local Nuclear Emergency Response Headquarters issued Directive titled as “Administration of the stable Iodine” to the Prefectural Governor and the heads of cities, towns and villages (Tomioka Town, Hutaba Town, Okuma Town, Namie Town, Kawauchi Village, Naraha Town, Minamisouma City, Tamura City, Kazurao Village, Hirono Town, Iwaki City and Iidate Village), which directs the above-mentioned governor and heads to administer stable Iodine under the direction of the headquarters and in the presence of medical experts, and not to administer it on personal judgements.

<Situation of the injured (As of 15:30 April 14th)>

1. Injury in Unit 1 of Fukushima Dai-ichi NPS due to earthquake on 11 March

- Two employees (slightly, have already returned to work)
 - Two employees (a cut by a broken glass by earthquake and tsunami, have already returned to work)
 - One employee (a scratch when evacuating, has already returned to work)
 - One subcontract employee (fracture in both legs, be in hospital)
 - Two died (After the earthquake, two TEPCO's employees missed and had been searched continuously. In the afternoon of March 30th, the two employees were found on the basement floor of the turbine building of Unit 4 and were confirmed dead by April 2nd.)
2. Injury due to the explosion of Unit 1 of Fukushima Dai-ichi NPS on 12 March
- Four employees (two TEPCO's employees and two subcontractor's employees) were injured at the explosion and smoke of Unit 1 around the turbine building (non-controlled area of radiation) and were examined by Kawauchi Clinic. Two TEPCO's employees return to work again and two subcontractors' employees are under home treatment.
3. Injury due to the explosion of Unit 3 of Fukushima Dai-ichi NPS on 14 March.
- Four TEPCO's employees (They have already returned to work.)
 - Three subcontractor's employees (They have already returned to work.)
 - Four members of Self-Defence Force (one of them was transported to National Institute of Radiological Sciences considering internal possible exposure. The examination resulted in no internal exposure. The member was discharged from the institute on March 17th.)
4. Other injuries
- On the earthquake on 11 March, one subcontractor's employees (a crane operator) died in Fukushima Dai-ichi NPS. (It seems that the tower crane broke and the operator room was crushed and the person was hit on the head.)
 - One subcontractor's employee was transported to the hospital on March 11th. (Later, turned out a cerebral infarction)
 - One emergency patient on 12 March. (a cerebral stroke, transported by the ambulance, be in hospital)

- Ambulance was requested for one employee complaining the pain at left chest outside of control area on March 12. (Conscious, under home treatment)
- One employee suffered lacerations on his left arm and was transported to the hospital for treatment on March 12th. (Has already returned to work)
- Two employees complaining discomfort wearing full-face mask in the main control room were transported to Fukushima Dai-ni NPS for a consultation with an industrial doctor on 13 March. (One employee has already returned to work and the other is under home treatment.)
- Two subcontractor's employees were injured during working at temporary control panel of power source in the Common Spent Fuel Pool, transported to where were industrial medical doctors the Fukushima Dai-ni NPS on 22 and 23 March. (One employee has already returned to work and the other is under home treatment.)
- On the afternoon of 7 April, a worker who was making sandbags at the soil disposal yard (spoil bank) on the north side of Fukushima Dai-ichi NPS got sick and was transported to J-Village for the body survey of contamination of radioactive materials. Being confirmed to be free from contamination, the worker was taken to the Iwaki City Kyouritsu Hospital by ambulance. On 8 April, the worker was diagnosed as dehydration and transient unconsciousness.
- At 09:19 April 9th, one subcontractor's employee was transported to a hospital as the worker wearing full-face mask felt discomfort during the work for cable processing in the Building of Water Processing, stepped on the manhole outside the building, which lid was shifted, and injured. As a result of medical examination, the worker was diagnosed as a right knee contusion and suspect of right knee medial collateral ligament injury. Furthermore, as a result of the body survey, it was confirmed that the worker was free from contamination of radioactive materials.
- Around 11:10 April 10th, a subcontractor's employee who was conducting the operations of laying drain hoses in the yard of Unit 2 got sick and was transported to J-Village. Thereafter the employee was taken to the Iwaki City Kyouritsu Hospital by ambulance at 14:27 on the same day. It was confirmed that the employee was free from adhesion of radioactive materials to his body

<Situation of resident evacuation (As of 15:30 April 14th)>

At 11:00 March 15th, the Prime Minister directed in-house stay to the residents in the area from 20 km to 30 km radius from Fukushima Dai-ichi NPS. The directive was conveyed to Fukushima Prefecture and related municipalities.

Regarding the evacuation as far as 20-km from Fukushima Dai-ichi NPS and 10-km from Fukushima Dai-ni NPS, necessary measures have already been taken.

- The in-house stay in the area from 20 km to 30 km from Fukushima Dai-ichi NPS is made fully known to the residents concerned.
- Cooperating with Fukushima Prefecture, livelihood support to the residents in the in-house stay area are implemented.
- On March 28th, Chief Cabinet Secretary mentioned the continuation of the limited-access within the area of 20 km from Fukushima Dai-ichi NPS. On the same day, the Local Nuclear Emergency Response Headquarters notified the related municipalities of forbidding entry to the evacuation area within the 20 km zone.

<Directives regarding foods and drinks>

Directive from the Director-General of the Government Nuclear Emergency Response Headquarters to the Prefectural Governors of Fukushima, Ibaraki, Tochigi and Chiba was issued, which directed above-mentioned governors to suspend shipment and so on of the following products for the time being.

The Government Nuclear Emergency Response Headquarters organized the thoughts of imposing and lifting restrictions on shipment as follows, considering the NSC's advice.

- The area where restrictions on shipment to be imposed or lifted could be decided in units of the area where a prefecture is divided into, such as cities, towns, villages and so on, considering the spread of the contamination affected area and the actual situation of produce collection, etc.
- The restriction on shipment of the item, of which the result of the sample test exceeded the provisional regulation limits, shall be decided by

- judging in a comprehensive manner considering the regional spread of the contamination impact.
- Lifting the restrictions on shipment shall be implemented when a series of three results of nearly weekly tests for the item or the area falls below the provisional regulation limits, considering the situation of the Fukushima Dai-ichi NPS.
 - However, the tests shall be carried out nearly weekly after the lifting, while the release of the radioactive materials from the NPS continues.

(1) Items under the suspension of shipment and restriction of intake (As of 15:30 April 14th)

Prefectures	Suspension of shipment	Restriction of intake
Fukushima Prefecture	Non-head type leafy vegetables, head type leafy vegetables, flowerhead brassicas (Spinach, Cabbage, Broccoli, Cauliflower, <i>Komatsuna</i> *, <i>Kukitachina</i> *, <i>Shinobufuyuna</i> *, Rape, <i>Chijirena</i> , <i>Santouna</i> *, <i>Kousaitai</i> *, <i>Kakina</i> *, etc.), Turnip, Raw milk (Except Kitakata-City, Bandai-Town, Inawashiro-Town, Mishima-Town, Aizumisato-Town, Shimogo-Town, Minamiaizu-Town) and Shiitake (only ones grown on raw lumber in an open field of Date-City, Souma-City, Minami-Souma-City, Tamura-City, Iwaki-City,	Non-head type leafy vegetables, head type leafy vegetables, flowerhead brassicas (Spinach, Cabbage, Broccoli, Cauliflower, <i>Komatsuna</i> *, <i>Kukitachina</i> *, <i>Shinobufuyuna</i> , Rape, <i>Chijirena</i> , <i>Santouna</i> *, <i>Kousaitai</i> *, <i>Kakina</i> *, etc.), Shiitake (only ones grown on raw lumber in an open field of Iitate Village)

	Sinchi-Town, Kawamata-Town, Namie-Town, Futaba-Town, Ookuma-Town, Tomioka-Town, Naraha-Town, Hirono-Town, Iitate-Village, Katsuo-Village and Kawauchi-Village)	
Ibaraki Pref.	Spinach, <i>Kakina</i> *, Parsley	
Tochigi Pref.	Spinach, <i>Kakina</i> *	
Chiba Pref.	- Spinach from Katori City and Tako Town - Spinach, Qing-geng-cai, Garland chrysanthemum, Sanchu Asian lettuce, Celery and Parsley from Asahi City	

*a green vegetable

(2) Request for restriction of drinking for tap-water (As of 15:30 April 14th)

Scope under restriction	Water service (Local governments requested for restriction)
All residents	None
Babies • Water services that continue to respond to the directive • Tap-water supply service that continues to respond to	<Fukushima Prefecture> Iitate small water service (Iitate Village, Fukushima Prefecture) None

the directive	
---------------	--

<Directive regarding the ventilation when using heating equipments in the area of indoor evacuation >

On March 21st, Directive titled as “Ventilation for using heating equipments within the in-house evacuation zone” from the Director-General of Local Nuclear Emergency Response Headquarters to the Prefectural Governor and the heads of cities, towns and villages (Tomioka Town, Hutaba Town, Okuma Town, Namie Town, Kawauchi Village, Naraha Town, Minamisouma City, Tamura City, Kazurao Village, Hirono Town, Iwaki City and Iitate Village) was issued, which directs those governor and heads to publicly announce the guidance to the residents within the in-house evacuation zone, concerning the indoor use of heating equipments that require ventilation, in order to avoid poisoning from carbon monoxide and to reduce exposure.

< Fire Bureaus’ Activities >

- From 11:00 till around 14:00 on March 22nd, Niigata City Fire Bureau and Hamamatsu City Fire Bureau gave guidance to TEPCO as to the set up of large decontamination system.
- From 8:30 till 9:30, from 13:30 till 14:30 on March 23rd, Niigata City Fire Bureau and Hamamatsu City Fire Bureau gave guidance to TEPCO as to the operation of large decontamination system.

(Contact Person)

Mr. Toshihiro Bannai

Director, International Affairs Office, NISA/METI
--

Phone:+81-(0)3-3501-1087

April 15, 2011

Nuclear and Industrial Safety Agency

Seismic Damage Information (the 94th Release)
(As of 08:00 April 15th, 2011)

Nuclear and Industrial Safety Agency (NISA) confirmed the current situation of Onagawa NPS, Tohoku Electric Power Co. Inc.; Fukushima Dai-ichi and Fukushima Dai-ni NPSs, Tokyo Electric Power Co. Inc. (TEPCO); Tokai Dai-ni NPS, Japan Atomic Power Co. Inc. as follows:

Major updates are as follows.

1. Nuclear Power Stations (NPSs)

● Fukushima Dai-ichi NPS

- Fresh water spray of 25t for Unit 3 using Concrete Pump Truck (50t/h) was carried out. (From 15:56 till 16:32 April 14th)
- Regarding Unit 4, the work for sampling water in the Spent Fuel Pool was carried out in order to grasp the conditions of the fuels that are kept in the pool. (From 12:00 till 13:04 April 12th) Nuclide analysis of radio active materials was carried out regarding the sampled water of the Spent Fuel Pool. (April 13th) As a result of nuclide analysis, $2.2 \times 10^2 \text{Bq/cm}^3$ of ^{131}I (Iodine), $8.8 \times 10^1 \text{Bq/cm}^3$ of ^{134}Cs (Caesium), $9.3 \times 10^1 \text{Bq/cm}^3$ of ^{137}Cs (Caesium) were detected. (April 14th)
- The test implementation of spraying antiscattering agent to prevent the spread of radioactive materials on the ground surface was carried out in the area of about 1,600 m² on the mountain-side of the Common Pool. (From 12:00 till 13:30 April 14th)
- In the 3 soil samples (6 samples in total) collected on 31 March and 4 April from the soil at the 3 points on the site of Fukushima Dai-ichi NPS where the regular sampling is to be carried out, ^{238}Pu (Plutonium), ^{239}Pu (Plutonium) and ^{240}Pu (Plutonium) were detected. (18:30 April 14th announced by TEPCO). The concentration of the detected plutonium was at the equivalent level of the fallout (radioactive fallout) that was observed in Japan concerning the past atmospheric nuclear testing, i.e. at

the equivalent level of the normal condition of environment, and was not at the level of having harmful influence on human body.

2. Actions taken by NISA

- NISA directed TEPCO orally to strengthen the monitoring of the Sub Drain (the groundwater collected and controlled in the facilities) of Units 1 and 2, because the radioactive concentration of the water sampled on 13 April rose one digit up in comparison with the preceding result.

For more information:

NISA English Home Page

<http://www.nisa.meti.go.jp/english/index.html>

April 15, 2011

Nuclear and Industrial Safety Agency

Seismic Damage Information (the 95th Release)
(As of 15:00 April 15th, 2011)

Nuclear and Industrial Safety Agency (NISA) confirmed the current situation of Onagawa NPS, Tohoku Electric Power Co. Inc.; Fukushima Dai-ichi and Fukushima Dai-ni NPSs, Tokyo Electric Power Co. Inc. (TEPCO); Tokai Dai-ni NPS, Japan Atomic Power Co. Inc. as follows:

Major updates are as follows.

1. Nuclear Power Stations (NPSs)

● Fukushima Dai-ichi NPS

- Fresh water spray over the Spent Fuel Pool of Unit 4 using Concrete Pump Truck (50t/h) was started. (14:08 April 15th).
- The temperature of water in the Common Spent Fuel Pool was around 33°C at 06:20 April 15th.
- Videotaping using an unmanned helicopter was carried out in order to grasp the situations of reactor buildings for Units 1 to 4. (From 08:02 till 09:55 April 15th)

2. Actions taken by NISA

(April 15th)

NISA strictly alerted TEPCO and directed it orally to prepare the measures for preventing the recurrence regarding the delay in the notification of the dismissal of Nuclear Emergency Preparedness Manager, accompanied with the personnel changes dated on 1 April, in accordance with Article 9, paragraph 5 of the Act on Special Measures Concerning Nuclear Emergency Preparedness.

April 16, 2011

Nuclear and Industrial Safety Agency

Seismic Damage Information (the 96th Release)
(As of 08:00 April 16th, 2011)

Nuclear and Industrial Safety Agency (NISA) confirmed the current situation of Onagawa NPS, Tohoku Electric Power Co. Inc.; Fukushima Dai-ichi and Fukushima Dai-ni NPSs, Tokyo Electric Power Co. Inc. (TEPCO); Tokai Dai-ni NPS, Japan Atomic Power Co. Inc. as follows:

Major updates are as follows.

1. Nuclear Power Stations (NPSs)

● Fukushima Dai-ichi NPS

- Fresh water spray of around 140t for Unit 4 using Concrete Pump Truck (50t/h) was started (From 14:30 till 18:29 April 15th)
- 3 sandbags filled with Zeolite were placed between the Inlet Screen Pump Room of Unit 3 and the Inlet Screen Pump Room of Unit 4. (From 14:30 till 15:45 April 15th)
- Temporary boards to stop water (4 steel plates out of 7) were installed on the ocean-side of the Inlet Bar Screen of Unit 2. (From 9:00 till 14:15 April 15th)
- The test implementation of spraying antiscattering agent to prevent the spread of radioactive materials on the ground surface was carried out in the area of about 1,900 m² on the mountain-side of the Common Pool. (From 11:30 till 13:00 April 15th)
- Removal of rubble (Amount equivalent to a container) using remote-control heavy machineries was carried out. (From 09:00 till 15:45 April 15th)
- As a countermeasure for tsunami, the distribution boards, etc. for the pumps injecting water to the reactors of Units 1 to 3 were transferred to a hill. (From 10:19 till 17:00 April 15)

2. Actions taken by NISA

- NISA directed General Electricity Utilities and other organizations concerned to consider the measures to ensure reliability on external power supply due to the temporary loss of external power supply at NPSs, etc. caused by ground faults in part of electric power system when the earthquake off the coast of Miyagi Prefecture occurred on April 7, 2011.

April 16, 2011

Nuclear and Industrial Safety Agency

Seismic Damage Information (the 97th Release)
(As of 15:00 April 16th, 2011)

Nuclear and Industrial Safety Agency (NISA) confirmed the current situation of Onagawa NPS, Tohoku Electric Power Co. Inc.; Fukushima Dai-ichi and Fukushima Dai-ni NPSs, Tokyo Electric Power Co. Inc. (TEPCO); Tokai Dai-ni NPS, Japan Atomic Power Co. Inc. as follows:

Major updates are as follows.

1. Nuclear Power Stations (NPSs)

● Fukushima Dai-ichi NPS

- From 11:00, 16 April, the test implementation of spraying antiscattering agent to prevent the spread of radioactive materials on the ground surface was carried out in the area of about 1,800 m² on the mountain-side of the Common Pool. It was finished at 13:00 on the same day.

April 17, 2011

Nuclear and Industrial Safety Agency

Seismic Damage Information (the 98th Release)
(As of 15:00 April 17th, 2011)

Nuclear and Industrial Safety Agency (NISA) confirmed the current situation of Onagawa NPS, Tohoku Electric Power Co. Inc.; Fukushima Dai-ichi and Fukushima Dai-ni NPSs, Tokyo Electric Power Co. Inc. (TEPCO); Tokai Dai-ni NPS, Japan Atomic Power Co. Inc. as follows:

Major updates are as follows.

1. Nuclear Power Stations (NPSs)

- Fukushima Dai-ichi NPS
 - Fresh water injection (Around 45t) to the Spent Fuel Pool via the Spent Fuel Pool Cooling Line of Unit 2 was carried out. (From 10:13 till 11:54 April 16th. Due to the occurrence of earthquake at around 11:19, the temporary motor-driven pump was stopped at 11:39. The Spent Fuel Pool was confirmed to be filled with water by the increase of Skimmer Level at 11:54.)
 - Regarding the Common Spent Fuel Pool, power supply was stopped due to short-circuiting of the end of the power supply circuit. (14:34 April 17th)
 - As of 06:10 April 16th, water temperature of the Common Spent Fuel Pool was around 33°C.
 - 2 sandbags filled with Zeolite were placed between the Inlet Screen Pump Room of Unit 1 and the Inlet Screen Pump Room of Unit 2 and 5 sandbags filled with Zeolite were placed between the Inlet Screen Pump Room of Unit 2 and the Inlet Screen Pump room of Unit 3. (From 9:00 till 11:15 April 17th)
 - Removal of rubble (Amount equivalent to 8 containers) using remote-control heaving machineries was carried out. (From 9:00 till 16:00 April 16th)

<Directives regarding foods and drinks>

Items under the suspension of shipment and restriction of intake were updated. (As of 15:00 April 17th)

For more information:

NISA English Home Page

<http://www.nisa.meti.go.jp/english/index.html>

April 18, 2011

Nuclear and Industrial Safety Agency

Seismic Damage Information (the 99th Release)
(As of 08:00 April 18th, 2011)

Nuclear and Industrial Safety Agency (NISA) confirmed the current situation of Onagawa NPS, Tohoku Electric Power Co. Inc.; Fukushima Dai-ichi and Fukushima Dai-ni NPSs, Tokyo Electric Power Co. Inc. (TEPCO); Tokai Dai-ni NPS, Japan Atomic Power Co. Inc. as follows:

Major updates are as follows.

1. Nuclear Power Stations (NPSs)

- Fukushima Dai-ichi NPS
 - Confirmation of situation, etc. using an unmanned robot at the reactor building of Unit 1 was carried out. (From 16:00 till 17:30 April 17th)
 - Confirmation of situation, etc. using an unmanned robot at the reactor building of Unit 3 was carried out. (From 11:30 till 14:00 April 17th)
 - In order to cool the Spent Fuel Pool of Unit 4, the Fresh water spray of around 140t using Concrete Pump Truck (62m class) was carried out. (From 17:39 till 21:22 April 17th)
 - Regarding the Common Spent Fuel Pool, power supply was stopped due to short-circuiting of the end of the power supply circuit. (14:34 April 17th) Thereafter the facility inspection was carried out and the power supply was recovered. (17:30 April 17th)
 - As of 05:15 April 17th, water temperature of the Common Spent Fuel Pool was around 34°C.
 - The test implementation of spraying anti-scattering agent to prevent the spread of radioactive materials on the ground surface was carried out, in the area of about 1,900 m² on the mountain-side of the Radioactive Waste Treatment Facilities (From 10:00 till 13:30 April

17th).

- Removal of rubble (Amount equivalent to 2 containers) using remote-control heavy machineries was carried out. (From 9:00 till 16:00 April 17th)

<Directives regarding foods and drinks>

Items under the suspension of shipment and restriction of intake were updated. (As of 08:00 April 18th)

April 18, 2011

Nuclear and Industrial Safety Agency

Seismic Damage Information (the 100th Release)
(As of 15:00 April 18th, 2011)

Nuclear and Industrial Safety Agency (NISA) confirmed the current situation of Onagawa NPS, Tohoku Electric Power Co. Inc.; Fukushima Dai-ichi and Fukushima Dai-ni NPSs, Tokyo Electric Power Co. Inc. (TEPCO); Tokai Dai-ni NPS, Japan Atomic Power Co. Inc. as follows:

Major updates are as follows.

1. Nuclear Power Stations (NPSs)

● Fukushima Dai-ichi NPS

- Confirmation of situation, etc. using an unmanned robot at the reactor building of Unit 2 was carried out. (From 13:42 till 14:33 April 18th)
- Fresh water spray over the Spent Fuel Pool of Unit 3 using Concrete Pump Truck (62m class) was started. (From 14:17 April 18th)
- In order to replace the hose used for water injection to the reactors of Units 1 to 3 with a new one, the pumps for water injection were stopped. (From 11:50 till 13:05 April 18th)
- The test implementation of spraying anti-scattering agent to prevent the spread of radioactive materials on the ground surface was carried out in the area of about 1,200m² around the Radioactive Waste Treatment Facilities. (From 09:00 till 14:30 April 18th)

April 19, 2011

Nuclear and Industrial Safety Agency

Seismic Damage Information (the 101th Release)
(As of 08:00 April 19th, 2011)

Nuclear and Industrial Safety Agency (NISA) confirmed the current situation of Onagawa NPS, Tohoku Electric Power Co. Inc.; Fukushima Dai-ichi and Fukushima Dai-ni NPSs, Tokyo Electric Power Co. Inc. (TEPCO); Tokai Dai-ni NPS, Japan Atomic Power Co. Inc. as follows:

Major updates are as follows.

1. Nuclear Power Stations (NPSs)

● Fukushima Dai-ichi NPS

- Fresh water spray of around 30t for Unit 3 using Concrete Pump Truck (62m class) was carried out. (From 14:17 till 15:02 April 18th)
- Removal of the rubble (Amounts equivalent to 4 containers) using remote-control heavy machineries was carried out. (From 09:00 till 16:00 April 18th)
- The watertight measures in the buildings of the Radioactive Waste Treatment Facilities were completed. (April 18th)

2. Action taken by NISA

NISA accepted (18 April) and confirmed (19 April) the report from TEPCO, in accordance with the direction for the collection of report issued on 10 April, concerning the transfer of the stagnant water with high-level radioactivity in Fukushima Dai-ichi NPS to the Radioactive Waste Treatment Facilities.

<Directives regarding foods and drinks>

Items under the suspension of shipment and restriction of intake were updated. (As 08:00 April 9th)

Tohoku Pacific Earthquake and the seismic damage to the NPSs

As of 8:00am April 18th, 2011 (JST)
Ministry of Economy, Trade and Industry

Earthquake and automatic shut-down of nuclear reactors

The Tohoku Pacific Earthquake of historic magnitude 9.0 struck the northeastern part of Japan at 14:46 on March 11th, 2011.

At the time of the earthquake occurrence, 3 reactors (Units 4, 5 and 6 at Fukushima Dai-ichi (I) Nuclear Power Station (NPS)) were under periodic inspection outage, and 11 reactors (Units 1, 2 and 3 at Onagawa NPS; Units 1, 2 and 3 at Fukushima I NPS; Units 1, 2, 3 and 4 of Fukushima Dai-ni (II) NPS; and an unit of Tokai Dai-ni (II) NPS) were automatically shut-down.

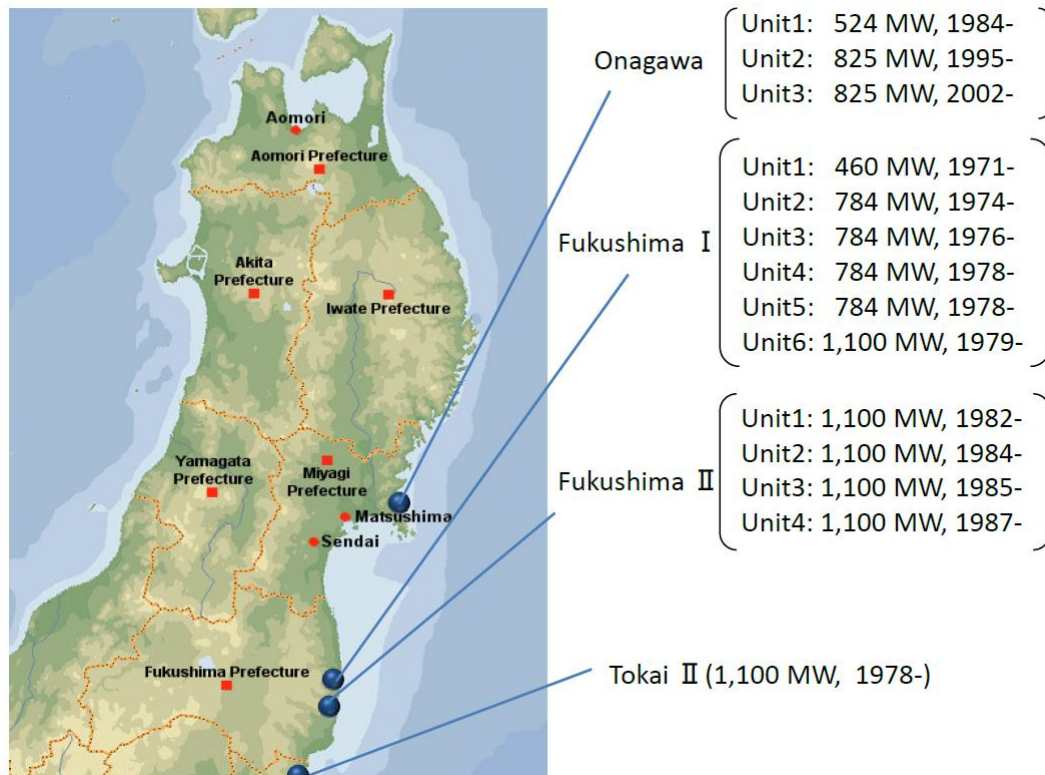

Tsunami damaged the emergency generators and the cooling systems at the Fukushima Dai-ichi (I)

Since the external power supply was cut off upon the earthquake occurrence, the emergency diesel power generators at Fukushima I automatically started generating electricity and the cooling systems began their operation.

Then, the massive earthquake triggered the devastating Tsunami wiping away houses, buildings, cars along the widespread areas of the northeast coast. The emergency diesel power generators and the pumps supplying seawater to the cooling system were halted at 15:41 on March 11th due to the Tsunami estimated more than 14 meters high from the seawater level.

Report concerning incidents at the Fukushima Dai-ichi (I)

Unit 1 Fresh water is being injected to the spent fuel pool and the reactor.

After the reactor was automatically shut-down and the Tsunami disabled the equipments. The pressure of containment vessel unusually increased and the water level inside the reactor pressure vessel dropped. Vent of the primary containment vessel was operated at 10:17am on March 12th; thereafter, hydrogen explosion occurred at the upper-part of the reactor building at 15:36.

Water injection to the reactor pressure vessel

- Seawater had been injected into the reactor pressure vessel since March 12th; thereafter, fresh water has been injected since March 25th, instead of seawater.

Water injection to the spent fuel pool

- On March 31st, spray of fresh water over the spent fuel pool of Unit 1 using the concrete pump truck was carried out.

Power supply

- Lighting in the main control room was recovered on March 24th. And the power supply for the fresh water injection to the reactor pressure vessel was switched to the external power supply on April 3rd.

Stagnant water

- As the result of concentration measurement in the stagnant water on the basement floor of the turbine building, $2.1 \times 10^5 \text{ Bq/cm}^3$ of ^{131}I (Iodine) and $1.8 \times 10^6 \text{ Bq/cm}^3$ of ^{137}Cs (Caesium) were detected as major radioactive nuclides. Since March 24th, the stagnant water has been transferred to the condenser until it was fulfilled.
- In order to prepare to transfer the stagnant water in the turbine building to the condenser, the water in the condensate storage tank was transferred to the surge tank of suppression pool water and finished on April 2nd. The transfer of the water in the condenser to the condensate storage tank was completed on April 10th.

Nitrogen injection

- Aiming at reducing the possibility of hydrogen combustion in the primary containment vessel of Unit 1, the operations for the injection of nitrogen to the vessel were started at 22:30 on April 6th. The start of nitrogen injection to the primary containment vessel of Unit 1 was confirmed. (1:31am April 7th)

Confirmation by unmanned robots

- Confirmation of situation, etc. was carried out by unmanned robots at the reactor building for Unit 1 on April 17th.

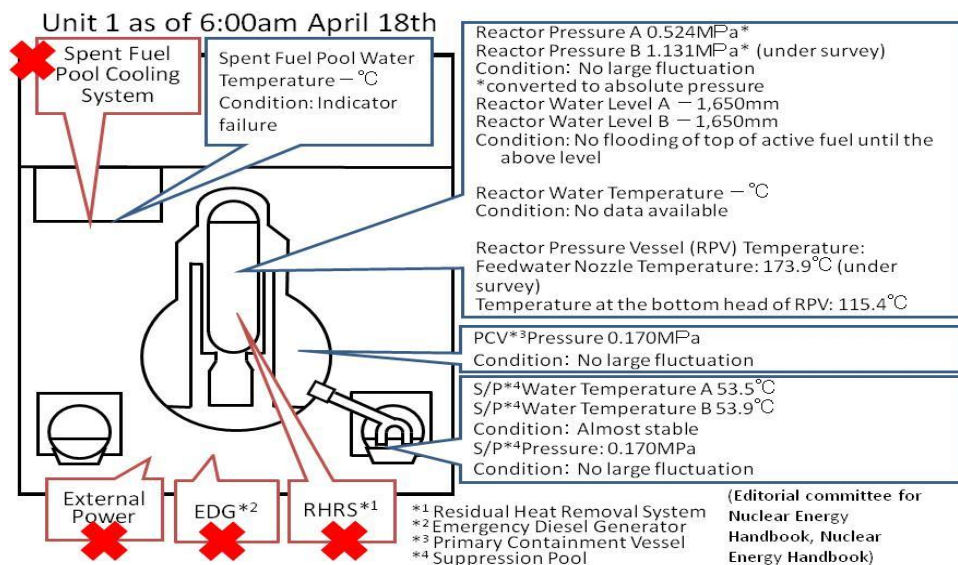

Unit 2 Fresh water is being injected to the spent fuel pool and the reactor.

After the automatic shut-down of the reactor, the water injection function was sustained. And vent of the primary containment vessel was operated at 11:00am on March 13th and at 0:02am on March 15th. But the reactor water level tended to decrease. At 6:10am on March 15th, there was an explosion sound at Unit 2. Given the fact that the pressure in the suppression chamber decreased, it is presumed that there is possibility of certain damage on the suppression chamber.

Water injection to the reactor pressure vessel

- Seawater had been injected into the reactor pressure vessel since March 14th; thereafter, fresh water has been injected since March 26th, instead of seawater.

Water injection to the spent fuel pool

- The seawater injection to the spent fuel pool using the fire pump truck started on March 20th. On March 29th, the injection was switched to the fresh water injection using the temporary motor-driven pump.

Power supply

- On March 26th, lighting of the main control room was recovered. And the power supply for the fresh water injection to the reactor pressure vessel was switched to the external power supply on April 3rd.

Stagnant water

- In order to prepare for transferring the stagnant water on the basement floor of turbine building to the condenser, the water in the condensate storage tank was transferred to the surge tank of suppression pool water from March 29th till April 1st. Thereafter, the water in the condenser was transferred to the condensate storage tank and completed on April 9th. The stagnant water in the trench of the turbine building was transferred to the condenser from April 12th till 13th.

Water in the pit

- The water, of which the dose rate was at the level of more than 1,000 mSv/h, was confirmed to be collected in the pit (a vertical portion of an underground structure) located near the intake channel of Unit 2. In addition, the outflow from the crack with a length of around 20 cm in the concrete portion of the lateral surface of the pit into the sea was confirmed on April 2nd. In order to stop the outflow, concrete was put inside, then high polymer absorbent etc. was used, but the outflow did not stop.
- After the coagulant (soluble glass) started to be injected from the holes around the pit on April 5th, the outflow of the water was confirmed to stop on April 6th. Furthermore, the measures to stop water by means of rubber board and jig (prop) were implemented at the outflowing point. (Finished on April 6th)

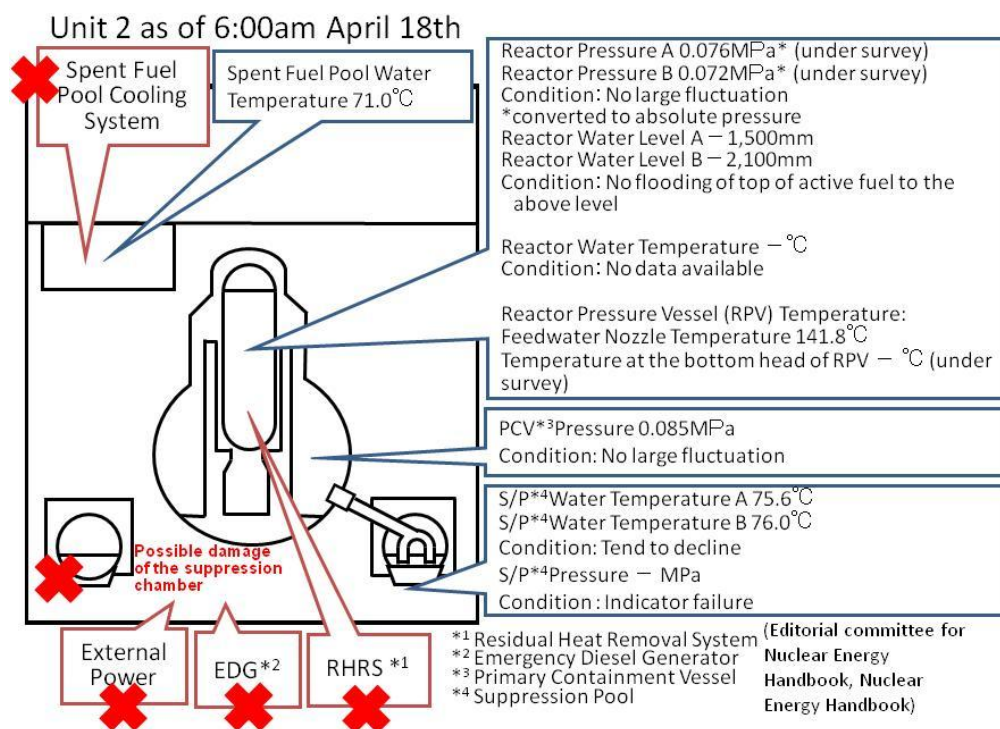

Unit 3 Fresh water is being injected to the spent fuel pool and the reactor.

After the automatic shut-down of the reactor, fresh water and subsequently seawater were injected into the reactor pressure vessel. And vent of the primary containment vessel was operated on March 13th and 14th. However, the pressure in the primary containment vessel rose up unusually and the explosion took place around the reactor building at 11:01am on March 14th.

Water injection to the reactor pressure vessel

- The seawater had been injected into the reactor pressure vessel since March 13th, thereafter; fresh water has been injected since March 25th, instead of seawater. On March 28th, the pump for the fresh water injection was switched from the fire pump truck to the temporary motor-driven pump.

Water injection to the spent fuel pool

- In order to pour water into the spent fuel pool, helicopters, water cannon trucks, fire engines and concrete pump trucks discharged water to the spent fuel pool of Unit 3 from sky and ground. Since March 29th till April 14th, fresh water spray over the spent fuel pool using the concrete pump truck had been carried out.

Power supply

- On March 22nd, lighting in the main control room was recovered. And the power supply for the fresh water injection to the reactor pressure vessel was switched to the external power supply on April 3rd.

Stagnant water

- In order to prepare for transferring the stagnant water on the basement floor of turbine building to the condenser, the water in the condensate storage tank is being transferred to the surge tank of suppression pool water from March 28th till March 31st.

Confirmation by unmanned robots

- Confirmation of situation, etc. was carried out by unmanned robots at the reactor building for Unit 3 on April 17th.

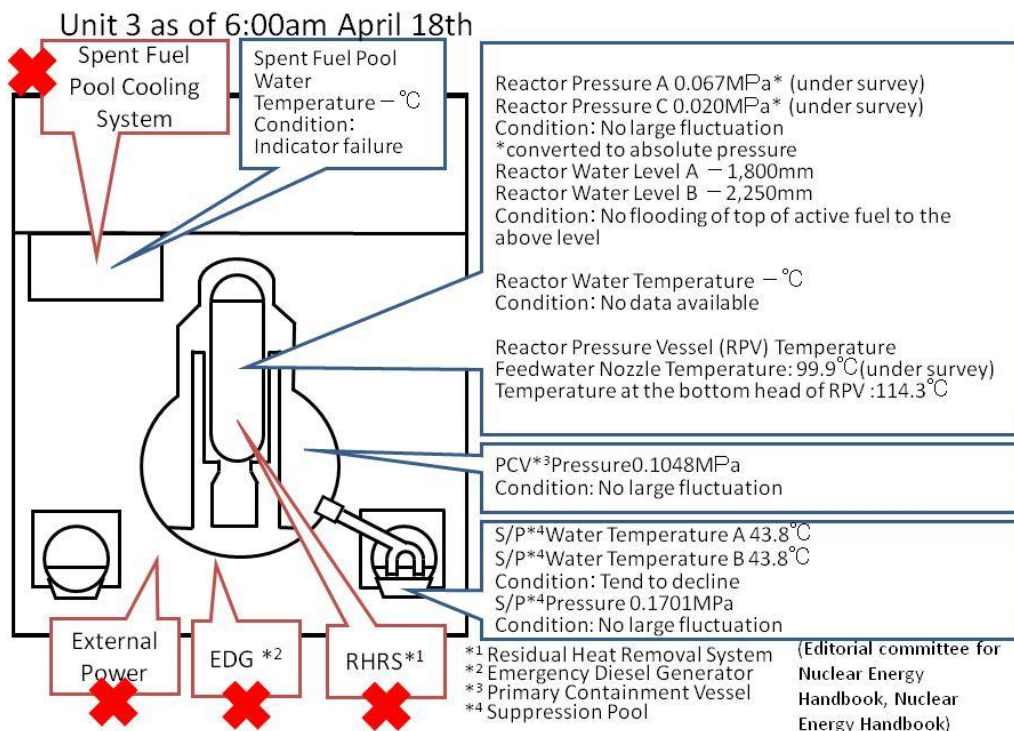

Unit 4 No fuel is in the reactor. Fresh water is being injected to the spent fuel pool.

There is no fuel in the reactor pressure vessel due to replacement of the shroud. It was confirmed that a part of wall of the operation floor of the reactor building of Unit 4 was damaged at 6:14am on March 15th. A fire took place at Unit 4 at 9:38am March 15th, but the fire was extinguished spontaneously as of 11:00am. Another fire took place on March 16th, but no fire could be confirmed from the ground.

Water injection to spent fuel pool

- Water spray using fire engine with seawater over the spent fuel pool of Unit 4 was carried out from March 20th till March 21st. And water spray using a concrete pump truck had been carried out five times with seawater from March 22nd till March 27th and nine times with fresh water from March 30th till April 17th.

Power supply

- On March 29th, lighting in the main control room was recovered.

Stagnant water

- From April 2nd, the stagnant water in the main building of radioactive waste treatment facilities was being transferred to the turbine building of Unit 4. As the water level in the vertical portion of the trench for Unit 3 rose from April 3rd, by way of precaution, the transfer was suspended notwithstanding that the path of the water was not clear.(9:22am April 4th)

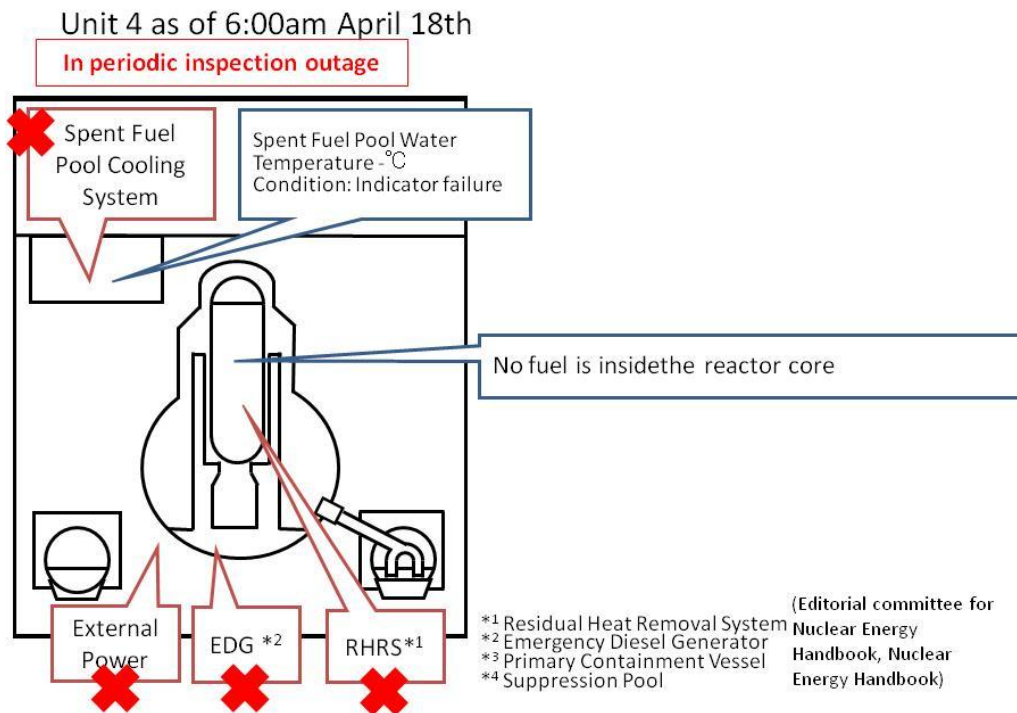

Unit 5&6 Unit 5 & 6 is under cold shut down.

One of the emergency generators for Unit 6 was operating and supplying electricity to Unit 5 and Unit 6. Fresh water was being injected into the reactor pressure vessels and the spent fuel pools by make-up water condensate system.

Cold shut down

- The pump for residual heat removal system (RHR) for Unit 5 and the pump for RHR for Unit 6 started up on March 19th and recovered heat removal function.
- Unit 5 was under cold shut down at 14:30 on March 20th and Unit 6 was under cold shut down at 19:27 on the same day.

Power supply

- Unit 5 and 6 received electricity reached to the starting transformer on March 20th. The power supply of Unit 5 and 6 was switched from the emergency diesel generators to the external power supply on March 21st and March 22nd.
- Power supply for the temporary pumps for RHR seawater system of Unit 5 and 6 were switched from the temporary to the permanent on March 24th and 25th.

Low-level radioactivity water discharge

- The groundwater with low-level radioactivity in the sub drain pits of Units 5 and 6 (around 1,300t) was discharged through the water discharge canal to the sea from April 4th till 9th in order to protect the critical safety facilities of the reactors. The water was beginning to leak out to the reactor building and other buildings of Unit 6 and there was no further capacity to accommodate it.

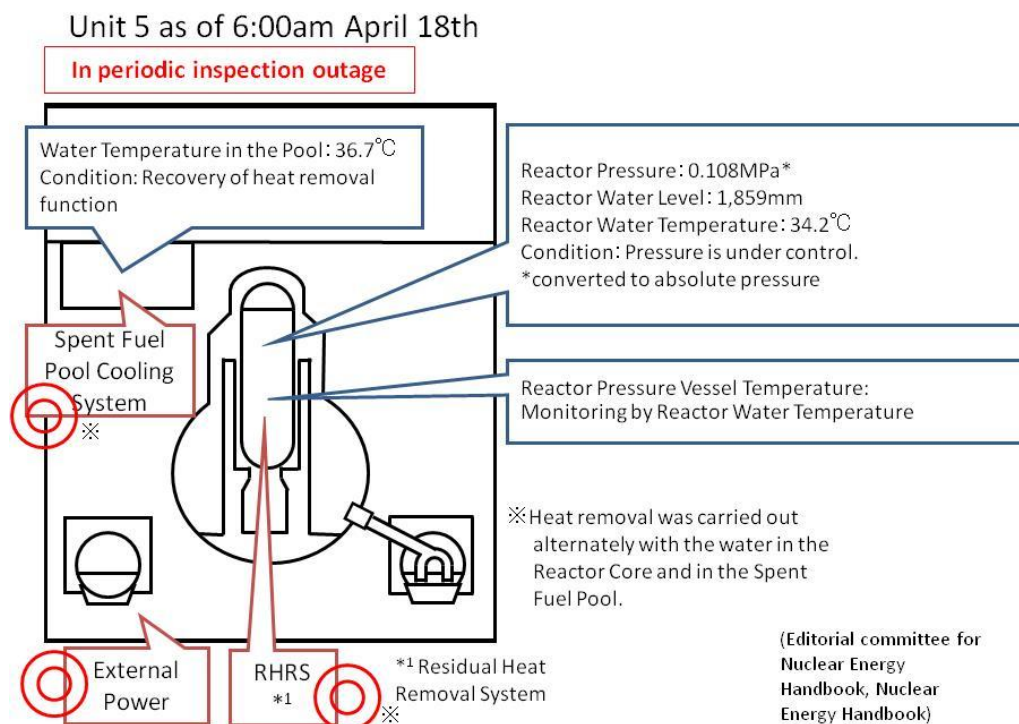

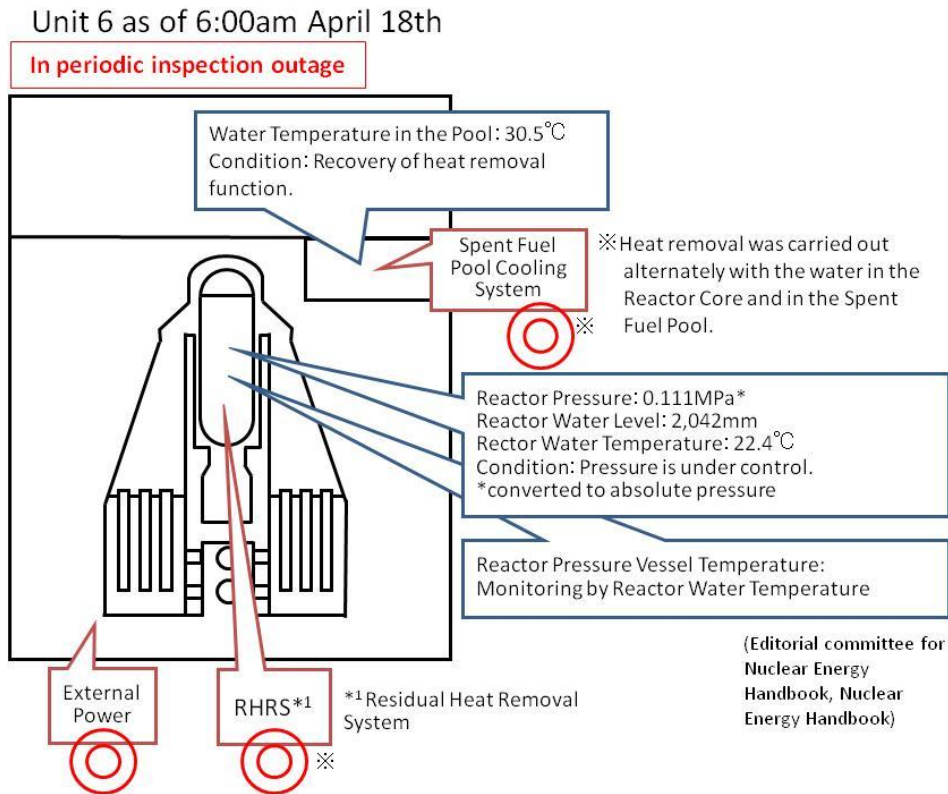

Common Spent Fuel Pool

- The power supply was started at 15:37 on March 24th and cooling was also started at 18:05 on the same day.
- The power supply was stopped due to short-circuiting of the end of the power supply circuit. (14:34 April 17th) Thereafter the facility inspection was carried out and the power supply was recovered. (17:30 April 17th)

Other

Nuclide analysis at water discharge canal

- As the result of nuclide analysis at around the southern water discharge canal, $7.4 \times 10^1 \text{ Bq/cm}^3$ of ^{131}I (1850.5 times higher than the limit of concentration of water outside the Environmental Monitoring Area) was detected on March 26th. (As the result of measurement on March 29th, it was detected as 3355.0 times higher than the limit in water.)
As the result of the analysis at the northern water discharge canal, $4.6 \times 10^1 \text{ Bq/cm}^3$ of ^{131}I (1262.5 times higher) was detected on March 29th.

Water in the trenches

- The water was confirmed to be collected in the vertical parts of the trenches (an underground structure for laying pipes, shaped like a tunnel) outside of the turbine building of Units 1 to 3. The dose rates on the water surface were 0.4 mSv/h of the Unit 1's trench and 1,000 mSv/h of the Unit 2's trench on March 27th. The rate of the Unit 3's trench could not measure because of the rubble.

Nuclide analysis of soil

- In the samples of soil collected on March 21st, 22nd, 25th, 28th, 31nd and April 4th

on the site of Fukushima I, ^{238}Pu (Plutonium), ^{239}Pu and ^{240}Pu were detected. The concentration of the detected plutonium was at the equivalent level of the fallout that was observed in Japan concerning the past atmospheric nuclear testing, i.e. at the equivalent level of the normal condition of environment, and was not at the level of having harmful influence on human body.

Stagnant water

- On March 28th, the stagnant water was confirmed in the main building of radioactive waste treatment facilities. As the result of analysis of radioactivity, the total amount of the radioactivity $1.2 \times 10^1 \text{ Bq/cm}^3$ in the controlled area and that of $2.2 \times 10^1 \text{ Bq/cm}^3$ in the non-controlled area were detected in March 29th.

Barges loading fresh water

- Two barges of the US armed forces carrying fresh water for cooling reactors, etc. landed in the exclusive port of the power station, being towed by the ships of Japan Maritime Self-Defense Force on March 31st and April 2nd. The transfer of fresh water from the barges to the filtrate tank was started.

Low-level radioactive water discharge

- The wastewater with high concentration of radioactive materials was trapped on the basement floor of the turbine building of Unit2 and it was necessary to immediately be transferred to another location as it was leaking out to the surrounding environment. But there was no further capacity to accommodate it.
- In order to use the main building of radioactive waste treatment facilities for accommodating the wastewater of the turbine building of Unit2, the stagnant water with low-level radioactivity in the radioactive waste treatment facilities was started to be discharged from the southern side of the water discharge canal to the sea from 19:03 April 4th till 10th. Confirmation of the remaining water is being carried out. (Total amount of discharged water is around 9,070t.)
- The stagnant water with low-level radioactivity in the building of miscellaneous solid waste volume reduction processing was discharged from the southern side of the water discharge canal to the sea using 5 pumps. (From 17:20 April 6th till 18:20 April 7th)

Other

- In order to prevent the contaminated water from outflowing from the exclusive port, the work for stopping water by means of large-sized sandbags was implemented around the seawall on the south side of the NPS on April 5th.
- 3 sandbags filled with Zeolite were placed between the inlet screen pump room of Unit 3 and that of Unit 4 on April 15th. Thereafter, 2 sandbags were placed between the inlet screen pump room of Unit 1 and that of Unit 2, and 5 sandbags were placed between that of Unit 2 and that of Unit 3 on April 17th.
- The silt fences to prevent the contaminated water from being scattered were completed to be doubly installed at the appropriate part of the seawall on the south side of the NPS on April 11th. Other silt fences were installed in front of the screen of Units 3 and 4 on April 13th, and at the curtain wall and in front of the screen of Unit 1 and 2 on April 14th.
- The test scattering of anti-scattering agent to prevent the radioactive materials on the ground surface from being scattered was carried out on the mountain-side of the Common Pool from April 1st till 17th.
- Removal of the rubble using remote-control heavy machineries was carried out from April 10th till 17th.
- On the ocean-side of the inlet bar screen of Unit 2, temporary boards to stop water were installed on April 12th, 13th and 15th.

Countermeasures for Tsunami

- The distribution boards, etc. for the pumps injecting water to the reactors of Units 1 to 3 were transferred to a hill on April 15th.

Current Situation

- Evacuation as far as 20 kilometers from Fukushima I NPS and 10 kilometers from Fukushima II NPS was almost completed (see the diagram “Fukushima prefecture”). The residents in the areas from 20 kilometers to 30 kilometers radius from Fukushima I NPS are directed to stay in-house.
- On March 16th, the Local Emergency Response Headquarter issued “the direction to administer the stable Iodine during evacuation from the evacuation area (20 km radius)” to the Prefecture Governors and the heads of cities, towns and villages.

Monitoring Data

1) The data of Monitoring Post out of 20 kilometers zone of Fukushima I NPS is available on the following website:

http://www.mext.go.jp/a_menu/saigaijohou/syousai/1303726.htm

2) The real-time radiation data collected via the System for Prediction of Environment Emergency Dose Information (SPEEDI) is available on the following website:

<http://www.bousai.ne.jp/eng/>

Location of Fukushima I and II in Japan

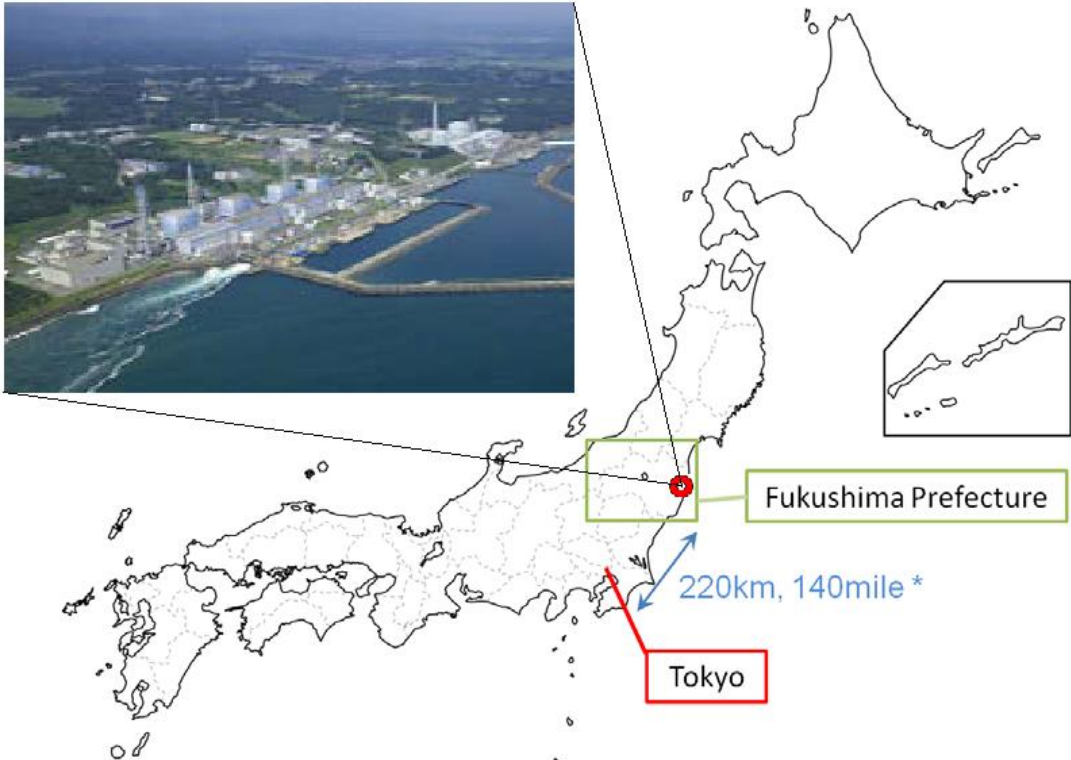

*Distance between Three Mile Island and Washington D.C. : 140km, 88mile

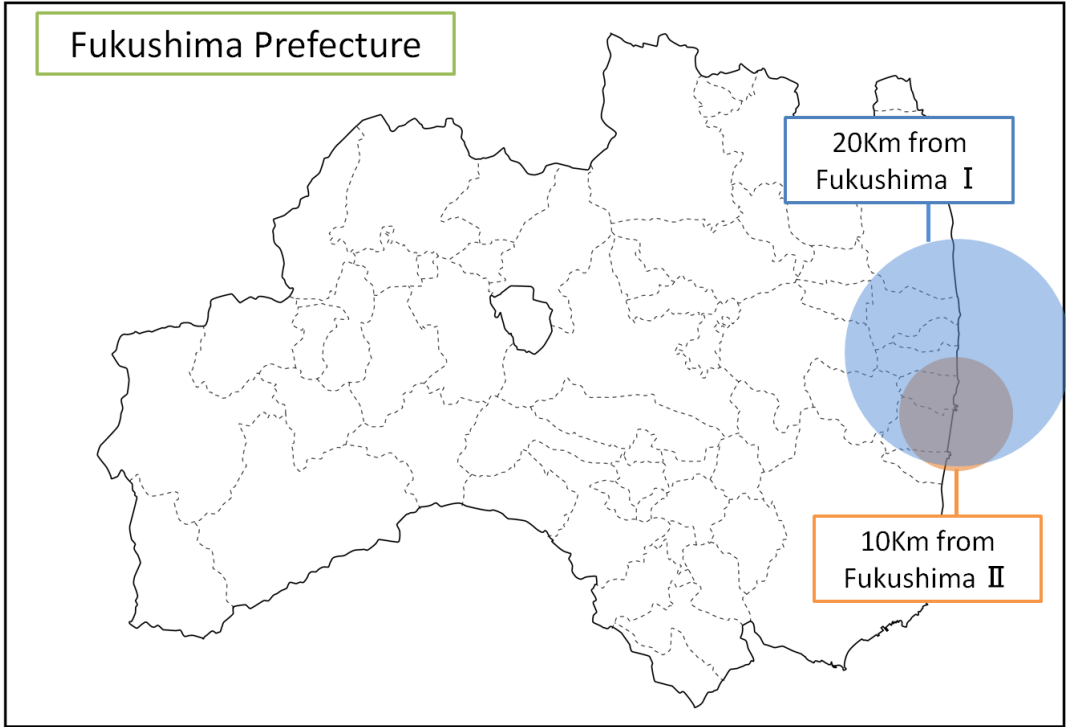

Conditions of Fukushima Dai-ichi Nuclear Power Station Unit 1 (As of 14:00 April 18th, 2011)

Major Events after the Earthquake

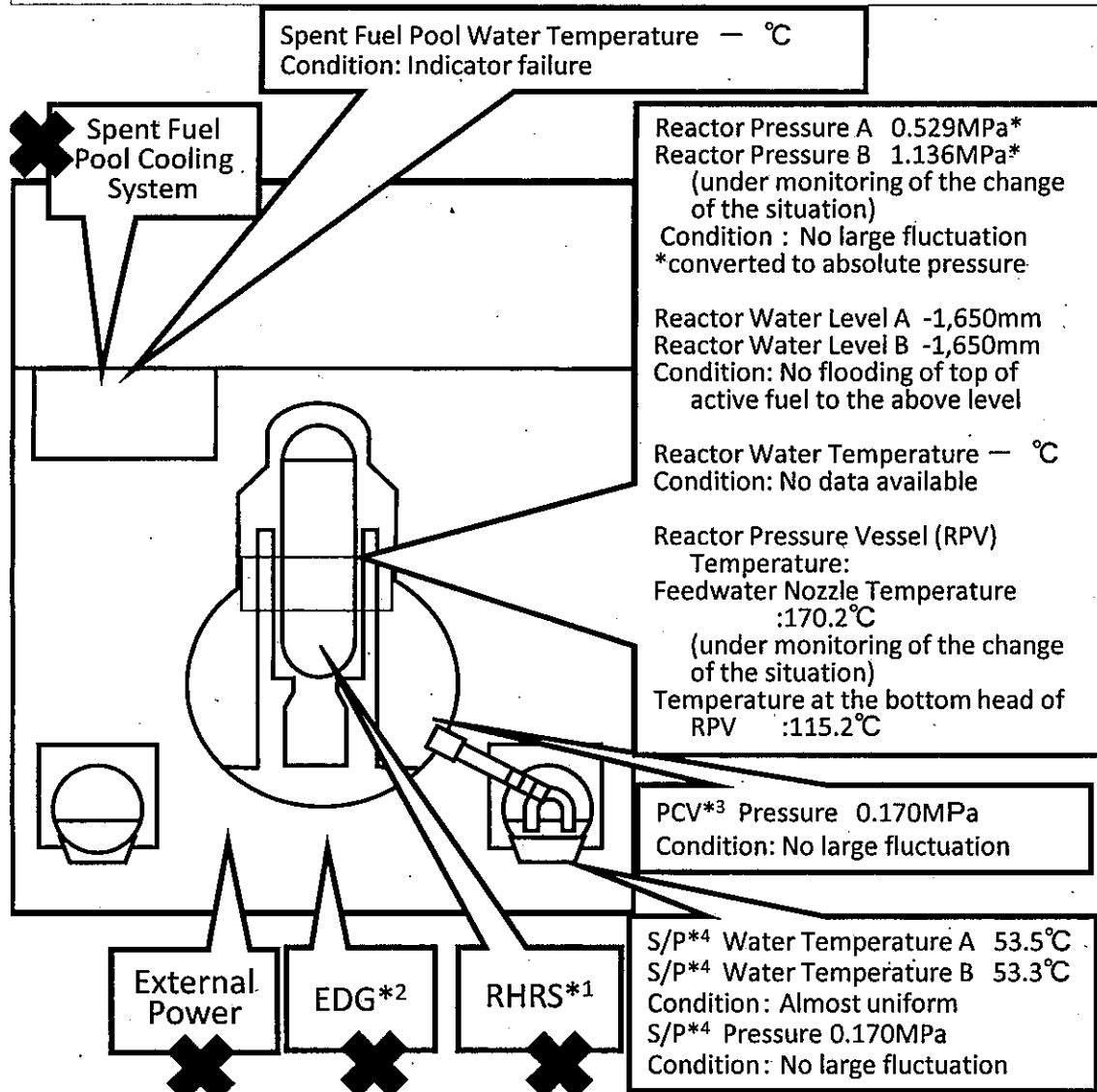

- March 11th 14:46 Under operation, Automatic shutdown by the earthquake
- March 11th 15:42 Report based on the Article 10 (Total loss of A/C power)
- March 11th 16:36 Occurrence of the Article 15 event (Inability of water injection of the Emergency Core Cooling System)
- March 12th 01:20 Occurrence of the Article 15 event (Unusual rise of the pressure in PCV)
- March 12th 10:17 Started to vent.
- March 12th 15:36 Sound of explosion
- March 12th 20:20 Started to inject seawater and borated water to the Reactor Core.
- March 23rd 02:33 The amount of injected water to the Reactor Core was increased utilizing the Feedwater Line in addition to the Fire Extinguish Line. (2m³/h →18m³/h)
- 09:00 Switched to the Feedwater Line only.(18m³/h →11m³/h)
- March 24th 11:30 Lighting in the Central Control Room was recovered.
- March 25th 15:37 Started to inject fresh water.
- March 29th 08:32 Switched to the water injection to the Reactor Core using the temporary motor-driven pump.
- March 31st 12:00 ~2nd 15:26 Started to transfer the stagnant water from the Condensate Storage Tank (CST) to the Surge Tank of Suppression Pool Water (SPT)
- March 31st 13:03~16:04 Water spray by Concrete Pump Truck (Fresh water)
- April 3rd 12:02 The power supply to the temporary motor-driven pump was switched from the temporary power supply to the external power supply.
- April 3rd 13:55 Started to transfer the water from the Condenser to CST.
- April 6th 22:30 Started the operation for the injection of nitrogen to PCV.
- April 7th 01:31 Confirmed starting the injection of nitrogen to PCV.
- April 9th 04:10 Started using highly pure nitrogen generator in the injection of nitrogen to PCV.
- April 10th 09:30 Completed transferring the water from the Condenser to CST.
- April 11th around 17:16 Loss of external power supply due to an earthquake occurred (at Hamadori in Fukushima Prefecture) and water injection to the Reactor Core and nitrogen injection to PCV were suspended.
- April 11th 17:56 External power supply was recovered.
- April 11th 18:04 Resumed injecting water to the Reactor Core.
- April 11th 23:19 Restarted operation for injecting nitrogen to PCV.
- April 11th 23:34 Confirmed starting injection of nitrogen to PCV.
- April 17th 16:00~17:30 Confirmed the situation in the reactor building using an unmanned robot.
- April 18th 11:50~12:12 Stopped the water injection into the reactor core to replace the current hose with a new one

- *1 Residual Heat Removal System
- *2 Emergency Diesel Generator
- *3 Primary Containment Vessel
- *4 Suppression Pool

Current Conditions : Fresh water is being injected to the Spent Fuel Pool and the Reactor Core

(Editorial committee for Nuclear Energy Handbook, Nuclear Energy Handbook)

Conditions of Fukushima Dai-ichi Nuclear Power Station Unit 2 (As of 14:00 April 18th, 2011)

Major Events after the Earthquake 1/2

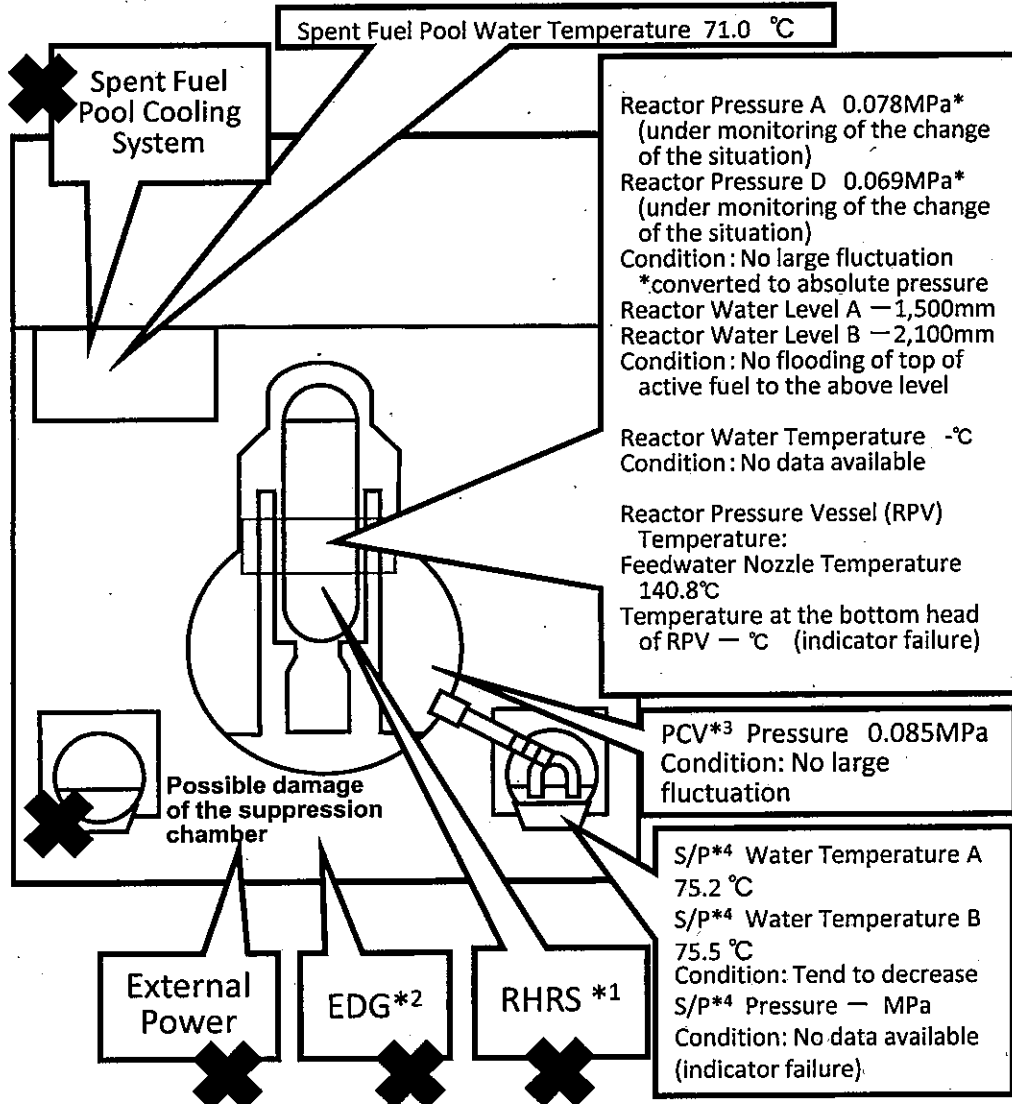

- March 11th 14:46 Under operation, Automatic shutdown by the earthquake
- March 11th 15:42 Report based on the Article 10 (Total loss of A/C power)
- March 11th 16:36 Occurrence of the Article 15 event (Inability of water injection of the Emergency Core Cooling System)
- March 13th 11:00 Started to vent.
- March 14th 13:25 Occurrence of the Article 15 event (Loss of reactor cooling functions)
- March 14th 16:34 Started to inject seawater to the Reactor Core.
- March 14th 22:50 Occurrence of the Article 15 event (Unusual rise of the pressure in PCV)
- March 15th 00:02 Started to vent.
- March 15th 06:10 Sound of explosion
- March 15th around 06:20 Possible damage of the suppression chamber
- March 20th 15:05 ~ 17:20 Approximately 40 ton seawater injection to the Spent Fuel Pool (SFP) via the Fuel Pool Cooling Line (FPC)
- March 20th 15:46 Power Center received electricity.
- March 21st 18:22 White smoke generated. The smoke died down and almost invisible at 07:11 March 22nd.
- March 22nd 16:07 Injection of around 18 tons of seawater to SFP
- March 25th 10:30 ~ 12:19 Sea water injection to SFP via FPC
- March 26th 10:10 Started to inject fresh water to the Reactor Core.
- March 26th 16:46 Lighting in the Central Control Room was recovered.
- March 27th 18:31 Switched to the water injection to the core using the temporary motor-driven pump.
- March 29th 16:30 ~ 18:25 Switched to the temporary motor-driven pump injecting fresh water to SFP.
- March 29th 16:45 ~ 1st 11:50 Transferred the water from the Condensate Storage Tank (CST) to the Surge Tank of Suppression Pool Water (SPT)
- March 30th 9:25 ~ 23:50 Confirmed malfunction of the temporary motor-driven pump injecting fresh water to SFP(9:45). Switched to the injection using the fire pump Truck, but suspended as cracks were confirmed in the hose. (12:47, 13:10) Resumed injection of fresh water(19:05)
- April 1st 14:56 ~ 17:05 Freshwater injection to SFP via FPC using the temporary motor-driven pump.
- April 2nd around 9:30 The water, of which the dose rate was at the level of more than 1,000mSv/h, was confirmed to be collected in the pit located near the Intake Channel of Unit 2. The outflow from the lateral surface of the pit into the sea was also confirmed.
- April 2nd 17:10 Started to transfer the water from the Condenser to the CST.
- April 3rd 12:12 The power supply to the temporary motor-driven pump was switched from the temporary power supply to the external power supply.
- April 3rd 13:47 ~ 14:30 20 bags of sawdust, 80 bags of high polymer absorbent and 3 bags of cutting-processed newspaper were put into the Pit for the Conduit.
- April 4th 7:08 ~ 7:11 Approximately 13kg of tracer (bath agent) was put in from the Pit for the Duct for Seawater Pipe.
- April 4th 11:05 ~ 13:37 Freshwater injection to SFP via FPC using the temporary motor-driven pump.
- April 5th 14:15 Tracer is confirmed to outflow through the permeable layer around the pit into the sea. 15:07 Started to inject coagulant.
- April 6th around 5:38 The water outflow from the lateral surface of the pit was confirmed to stopped.
- April 7th 13:29 ~ 14:34 Freshwater injection to SFP via FPC (Around 36 ton)
- April 9th 13:10 Completed transferring the water from the Condenser to CST.
- April 10th 10:37 ~ 12:38 Freshwater injection to SFP via FPC using the temporary motor-driven pump (Around 60 ton).
- April 11th around 17:16 Loss of external power supply due to an earthquake occurred (at Hamadori in Fukushima Prefecture). Water injection to the Reactor Core was suspended.
- April 11th 17:56 External power supply was recovered.
- April 11th 18:04 Resumed injecting water to the Reactor Core.

Current Conditions: Fresh water is being injected to the Spent Fuel Pool and the Reactor Core

- *1 Residual Heat Removal System
- *2 Emergency Diesel Generator
- *3 Primary Containment Vessel
- *4 Suppression Pool

Major Events after the Earthquake 2/2

April 12th 19:35~April 13th 17:04 Transfer from the trench of the turbine building to the Condenser.

April 13th 11:00 Suspended the transfer for checking leaks, etc.

April 13th 13:15~14:55 Freshwater injection to SFP via FPC using the temporary motor-driven pump.

April 16th 10:13~11:54 Freshwater injection to SFP via FPC using the temporary motor-driven pump. (The temporary motor-driven pump stopped at 11:39 due to an earthquake that occurred at around 11:19. SFP was confirmed to be filled to capacity through observing a rise of the water level in the Skimmer Tank.)

April 16th around 11:19 An earthquake occurred (in the southern part of Ibaraki Prefecture).

April 18th 13:42~ Confirmed the situation in the reactor building using an unmanned robot.

April 18th 12:13~12:37 Stopped the water injection into the reactor core to replace the current hose with a new one.

Conditions of Fukushima Dai-ichi Nuclear Power Station Unit 3

(As of 14:00 April 18th, 2011)

Major Events after the Earthquake

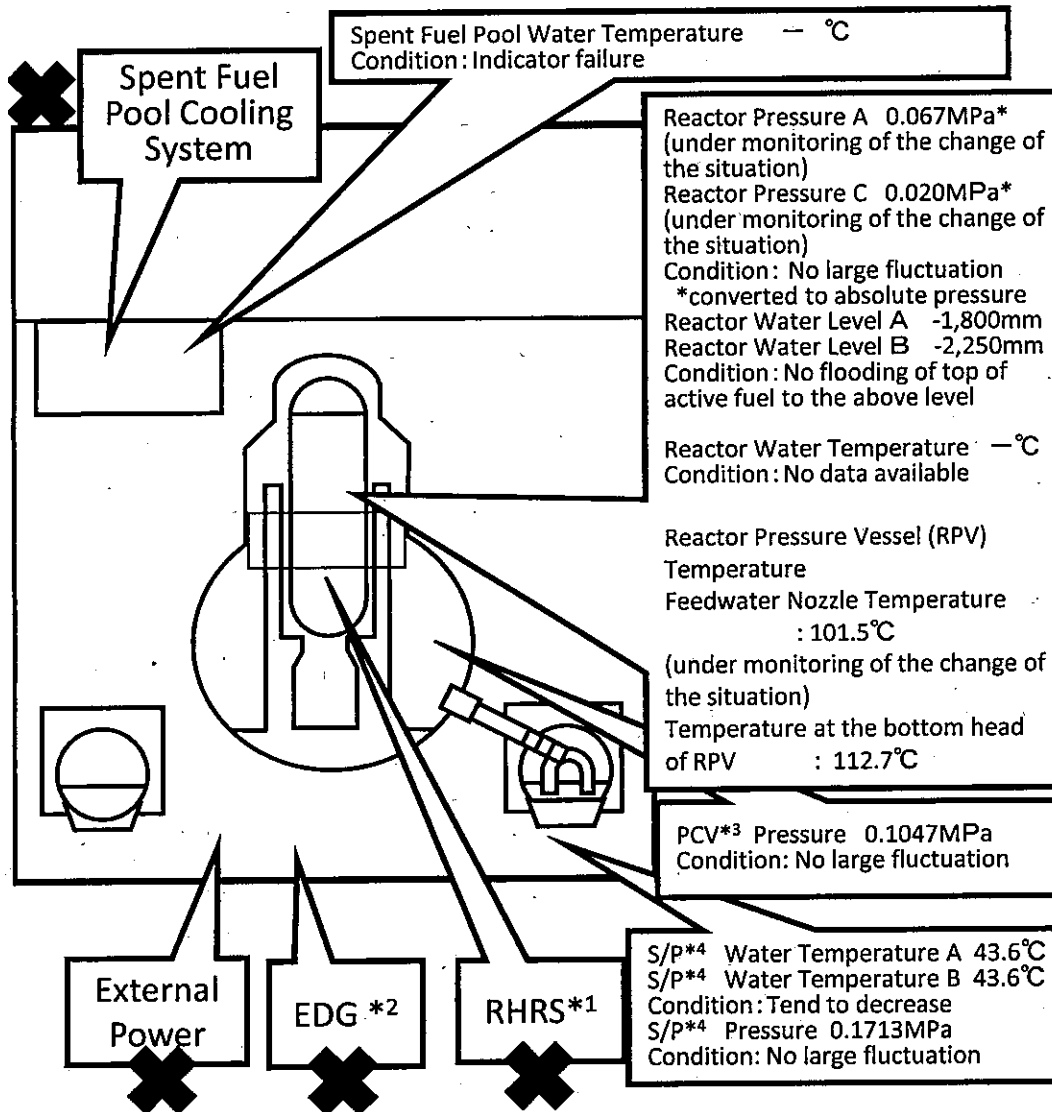

March 11th 14:46 Under operation, Automatic shutdown by the earthquake
 March 11th 15:42 Report based on the Article 10 (Total loss of A/C power)
 March 13th 05:10 Occurrence of the Article 15 event (Inability of water injection of the Emergency Core Cooling System)
 March 13th 08:41 Started to vent.
 March 13th 13:12 Started to inject seawater and borated water to the Reactor Core.
 March 14th 05:20 Started to vent.
 March 14th 07:44 Occurrence of the Article 15 event (Unusual rise of the pressure in-PCV)
 March 14th 11:01 Sound of explosion
 March 16th around 08:30 White smoke generated.
 March 17th 09:48 ~ 10:01 Water discharge by the helicopters of Self-Defense Force
 March 17th 19:05 ~ 19:15 Water spray from the ground by High pressure water-cannon trucks of Police
 March 17th 19:35 ~ 20:09 Water spray from the ground by fire engines of Self-Defense Force
 March 18th before 14:00 ~ 14:38 Water spray from the ground by 6 fire engines of Self-Defense Force
 March 18th ~ 14:45 Water spray from the ground by a fire engine of the US Military
 March 19th 00:30 ~ 01:10 Water spray by Hyper Rescue Unit of Tokyo Fire Department
 March 19th 14:10 ~ 20th 03:40 Water spray by Hyper Rescue Unit of Tokyo Fire Department
 March 20th 11:00 Pressure of PCV rose(320kPa). Afterward fell.
 March 20th 21:36 ~ 21st 03:58 Water spray by Hyper Rescue Unit of Tokyo Fire Department
 March 21st around 15:55 Grayish smoke generated and was confirmed to be died down at 17:55.
 March 22nd 15:10 ~ 16:00 Water spray by Hyper Rescue Unit of Tokyo Fire Department and Osaka City Fire Bureau.
 March 22nd 22:46 Lighting in the Central Control Room was recovered.
 March 23rd 11:03 ~ 13:20 Injection of about 35 ton of sea water to the Spent Fuel Pool (SFP) via the Fuel Pool Cooling Line (FPC)
 March 23rd around 16:20 Black smoke generated and was confirmed to died down at around 23:30 and 24th 04:50.
 March 24th 05:35 ~ 16:05 Injection of around 120 ton of sea water to SFP via FPC
 March 25th 13:28 ~ 16:00 Water spray by Kawasaki City Fire Bureau supported by Tokyo Fire Department
 March 25th 18:02 Started fresh water injection to the core.
 March 27th 12:34 ~ 14:36 Water spray by Concrete Pump Truck
 March 28th 17:40 ~ 31st around 8:40 Transferring the water from the Condensate Storage Tank (CST) to the Surge Tank of Suppression Pool Water (SPT)
 March 28th 20:30 Switched to the water injection to the core using a temporary motor-driven pump.
 April 3rd 12:18 The power supply to the temporary motor-driven pump was switched from the temporary power supply to the external power supply.
 April 11th around 17:16 Loss of external power supply of Unit 1 and 2 due to an earthquake occurred (at Hamadori in Fukushima Prefecture) and water injection to the Reactor Core was suspended.
 April 11th 18:04 External power supply of Units 1 and 2 recovered (April 11th 17:56). Resumed injecting water to the Reactor Core.
 April 17th 11:30 ~ 14:00 Confirmed the situation in the reactor building using unmanned robot.
 April 18th 12:38 ~ 13:05 Stopped the water injection into the reactor core to replace the current hose with a new one
 <Water spray by Concrete Pump Truck (Fresh water)>
 March 29th 14:17 ~ 18:18, March 31st 16:30 ~ 19:33, April 2nd 09:52 ~ 12:54, April 4th 17:03 ~ 19:19, April 7th 06:53 ~ 08:53, April 8th 17:06 ~ 20:00, April 10th 17:15 ~ 19:15, April 12th 16:26 ~ 17:16, April 14th 15:56 ~ 16:32

- *1 Residual Heat Removal System
- *2 Emergency Diesel Generator
- *3 Primary Containment Vessel
- *4 Suppression Pool

Current Conditions: Fresh water is being injected to the Spent Fuel Pool and the Reactor Core

Conditions of Fukushima Dai-ichi Nuclear Power Station Unit 4 (As of 14:00 April 18th, 2011)

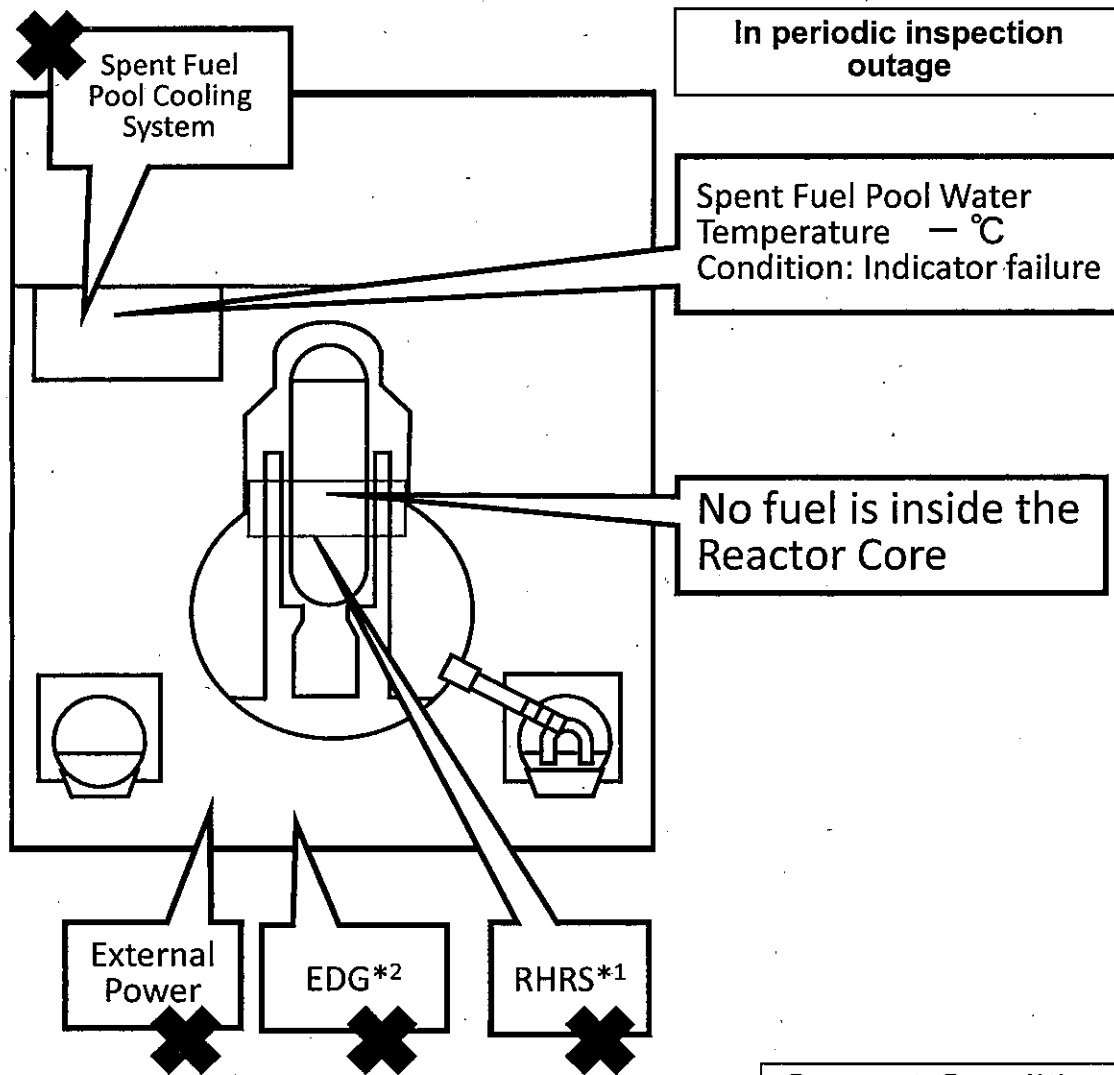

- *1 Residual Heat Removal System
- *2 Emergency Diesel Generator
- *3 Reactor Pressure Vessel

Major Events after the Earthquake

In periodic inspection outage when the earthquake occurred
 March 14th 04:08 Water temperature in the Spent Fuel Pool (SFP), 84°C
 March 15th 06:14 Confirmed the partial damage of wall in the 4th floor.
 March 15th 09:38 Fire occurred in the 3rd floor. (12:25 extinguished)
 March 16th 05:45 Fire occurred. TEPCO couldn't confirm any fire on the ground. (06:15)
 March 20th 08:21~09:40 Water spray over SFP by Self-Defense Force
 March 20th around 18:30~19:46 Water spray over SFP by Self-Defense Force
 March 21st 06:37~08:41 Water spray over SFP by Self-Defense Force
 March 21st around 15:00 Work for laying cable to Power Center was completed.
 March 22nd 10:35 Power Center received electricity.
 <Water spray by Concrete Pump Truck (Seawater)>
 March 22nd 17:17~20:32, March 23rd 10:00~13:02, March 24th 14:36~17:30, March 25th 19:05~22:07, March 27th 16:55~19:25
 March 25th 06:05~10:20 Sea water injection to SFP via the Fuel Pool Cooling Line (FPC)
 March 29th 11:50 Lighting in the Central Control Room was recovered.
 April 11th around 17:16 An earthquake occurred (at Hamadori in Fukushima Prefecture).
 April 12th 12:00~13:04 Sampled the water in SFP.

< Water spray by Concrete Pump Truck (Fresh water)> March 30th 14:04~18:33, April 1st 08:28~14:14, April 3rd 17:14~22:16, April 5th 17:35~18:22, April 7th 18:23~19:40, April 9th 17:07~19:24, April 13th 0:30~6:57, April 15th 14:30~18:29, April 17th 17:39~21:22

**Current Conditions: No fuel is in RPV*3.
Fresh water is being injected to the Spent Fuel Pool.**

(Editorial committee for Nuclear Energy Handbook, Nuclear Energy Handbook)

Conditions of Fukushima Dai-ichi Nuclear Power Station Unit 5 (As of 14:00 April 18th, 2011)

In periodic inspection outage

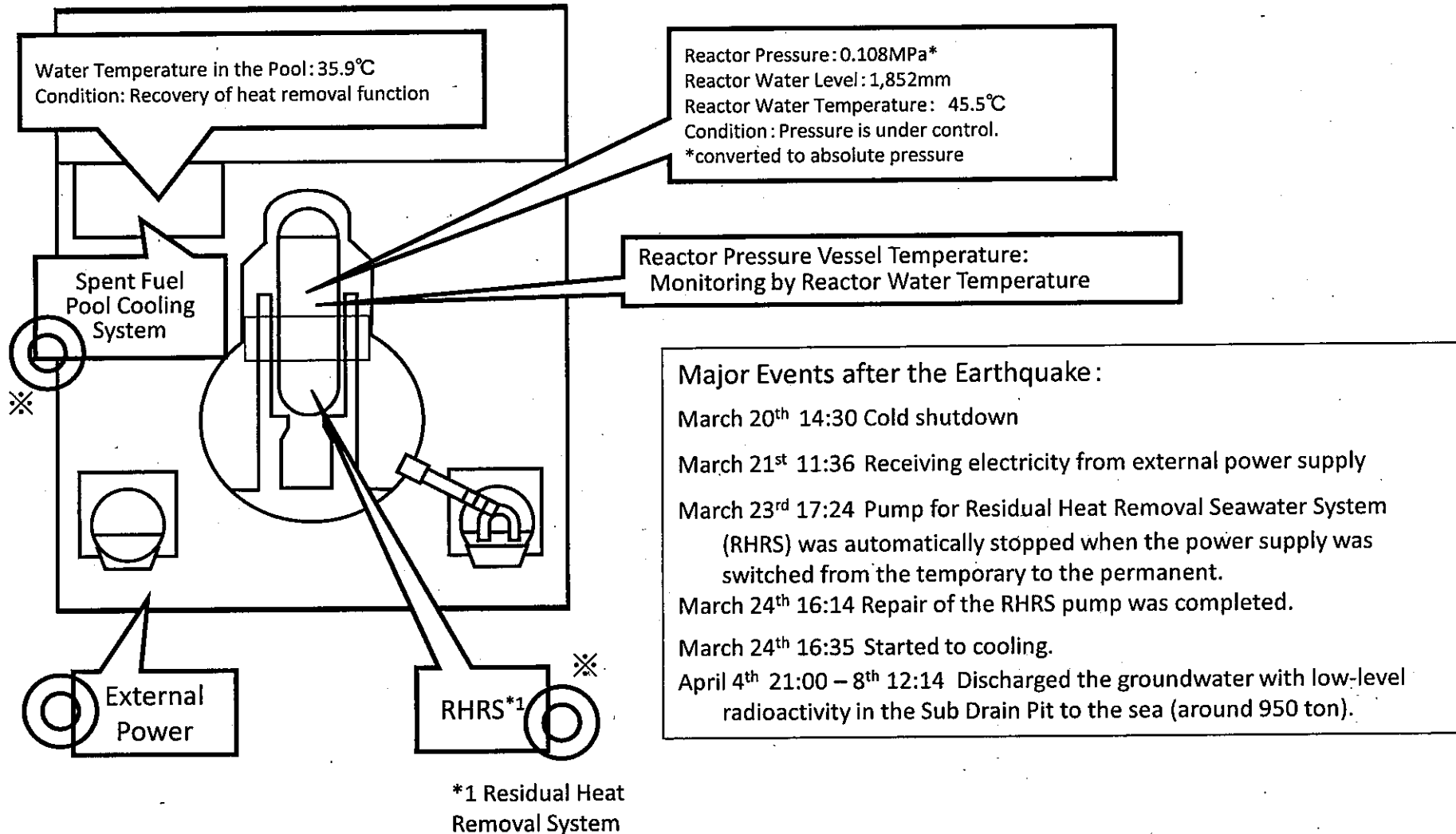

Major Events after the Earthquake:

- March 20th 14:30 Cold shutdown
- March 21st 11:36 Receiving electricity from external power supply
- March 23rd 17:24 Pump for Residual Heat Removal Seawater System (RHRS) was automatically stopped when the power supply was switched from the temporary to the permanent.
- March 24th 16:14 Repair of the RHRS pump was completed.
- March 24th 16:35 Started to cooling.
- April 4th 21:00 – 8th 12:14 Discharged the groundwater with low-level radioactivity in the Sub Drain Pit to the sea (around 950 ton).

※Heat removal was carried out alternately with the water in the Reactor Core and in the Spent Fuel Pool.

Conditions of Fukushima Dai-ichi Nuclear Power Station Unit 6 (As of 14:00 April 18th, 2011)

